

# Service Manual

Stereo Tuner

FM/AM Stereo Tuner (ST-Z200)  
FM/MW/LW Stereo Tuner (ST-Z200L)

## ST-Z200/ ST-Z200L

ST-Z200



ST-Z200L

## Color

(K)...Black Type  
(S)...Silver Type

Color	Area
(K)(S)	[EX]...Switzerland, Scandinavia (ST-Z200/ST-Z200L)
(K)(S)	[EH]...Holland (ST-Z200)
(K)(S)	[XA]...Southeast Asia, Oceania, Africa, Middle Near East, Central South America (ST-Z200)
(K)	[PA]...Far East PX (ST-Z200)
(K)	[PE]...European Military (ST-Z200)
(K)(S)	[XL]...Australia (ST-Z200)
(K)(S)	[EK]...United Kingdom (ST-Z200L)
(K)(S)	[EF]...France (ST-Z200L)
(K)(S)	[EB]...Belgium (ST-Z200L)

## SPECIFICATIONS

(DIN 45 500)

### ■ FM TUNER SECTION

Frequency range	88~108 MHz
Sensitivity	0.95 $\mu$ V (IHF, usable)
S/N 30 dB	1.0 $\mu$ V (75 $\Omega$ )
S/N 26 dB	0.9 $\mu$ V (75 $\Omega$ )
S/N 20 dB	0.8 $\mu$ V (75 $\Omega$ )
IHF 46 dB stereo quieting sensitivity	22 $\mu$ V/75 $\Omega$
Total harmonic distortion	
MONO	0.15%
STEREO	0.3%
S/N	
MONO	70 dB (78 dB, IHF)
STEREO	65 dB (70 dB, IHF)
Frequency response	20 Hz~15 kHz, +0.5 dB~-1.5 dB
Alternate channel selectivity ( $\pm$ 400 kHz)	65 dB
Capture ratio	1.0 dB
Image rejection at 98 MHz	40 dB
IF rejection at 98 MHz	70 dB
Spurious response rejection at 98 MHz	70 dB
AM suppression	50 dB
Stereo separation	
1 kHz	40 dB
10 kHz	30 dB
Carrier leak	
19 kHz	-30 dB (-35 dB, IHF)
38 kHz	-45 dB (-50 dB, IHF)
Channel balance (250 Hz~6,300 Hz)	$\pm$ 1.5 dB

Limiting point	1.2 $\mu$ V
Bandwidth	
IF amplifier	180 kHz
FM demodulator	1000 kHz
Antenna terminals	75 $\Omega$ (unbalanced)

### ■ AM TUNER SECTION (ST-Z200)

Frequency range	525~1605 kHz
Sensitivity (S/N 20 dB)	20 $\mu$ V, 300 $\mu$ V/m
Selectivity ( $\pm$ 10 kHz)	27 dB
Image rejection at 1,000 kHz	40 dB
IF rejection at 1,000 kHz	65 dB

### ■ AM TUNER SECTION (ST-Z200L)

Frequency range	
MW	525~1605 kHz
LW	145~350 kHz
Sensitivity (S/N 20 dB)	
MW	20 $\mu$ V, 300 $\mu$ V/m
LW	50 $\mu$ V
Selectivity	
MW ( $\pm$ 10 kHz)	27 dB
LW (250 kHz)	35 dB
Image rejection	
MW	40 dB (1000 kHz)
LW	40 dB (250 kHz)
IF rejection	
MW	65 dB (1000 kHz)
LW	40 dB (250 kHz)

# Technics

Panasonic Tokyo  
Matsushita Electric Industrial Co., Ltd.  
1-2, 1-chome, Shibakoen, Minato-ku, Tokyo 105 Japan

Matsushita Electric Trading Co., Ltd.  
P.O. Box 288, Central Osaka Japan

**GENERAL**

Output voltage 0.3V (0.6V IHF)  
 Power consumption 6W  
 Power supply  
 For Australia and United Kingdom AC 50 Hz/60 Hz, 240V  
 For continental Europe AC 50 Hz/60 Hz, 220V  
 For others AC 50 Hz/60 Hz, 110V/120V/220V/240V

Dimensions (W×H×D) 430 × 53 × 242 mm  
 (16-15/16" × 2-3/32" × 9-17/32")  
 Weight 2.4 kg (5.3 lb.)

• Specifications are subject to change without notice for further improvement.

**CONTENTS**

	Page
SAFETY PRECAUTION . . . . .	2
LOCATION OF CONTROLS . . . . .	3
DISASSEMBLY INSTRUCTIONS . . . . .	4
DIAL CORD INSTALLATION GUIDE . . . . .	4
MEASUREMENTS AND ADJUSTMENTS . . . . .	5 ~ 7
RESISTORS AND CAPACITORS . . . . .	8

	Page
<b>CIRCUIT BOARDS AND WIRING CONNECTION DIAGRAM</b>	
MODEL ST-Z200 . . . . .	9, 10
MODEL ST-Z200L . . . . .	11, 12
BLOCK DIAGRAM . . . . .	13, 14
SCHEMATIC DIAGRAM . . . . .	15 ~ 17
REPLACEMENT PARTS LIST . . . . .	18, 19
EXPLODED VIEW . . . . .	19, 20

**SAFETY PRECAUTION**

1. Before servicing, unplug the power cord to prevent an electric shock.
2. When replacing parts, use only manufacturer's recommended components for safety.
3. Check the condition of the power cord. Replace if wear or damage is evident.
4. After servicing, be sure to restore the lead dress, insulation barriers, insulation papers, shields, etc.
5. Before returning the serviced equipment to the customer, be sure to make the following insulation resistance test to prevent the customer from being exposed to a shock hazard.

**INSULATION RESISTANCE TEST**

1. Unplug the power cord and short the two prongs of the plug with a jumper wire.
2. Turn on the power switch.
3. Measure the resistance value with ohmmeter between the jumpered AC plug and each exposed metal cabinet part, such as screwheads antenna, control shafts, handle brackets, etc. Equipment with antenna terminals should read between 3MΩ and 5.2MΩ to all exposed parts. (Fig. A) Equipment without antenna terminals should read approximately infinity to all exposed parts. (Fig. B)

**Note:** Some exposed parts may be isolated from the chassis by design. These will read infinity.

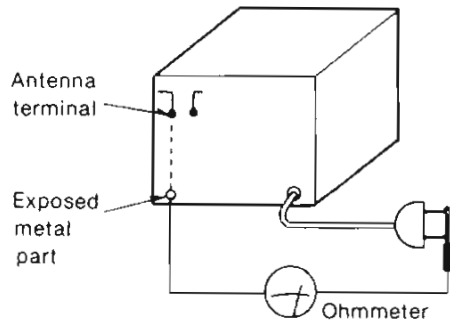

(Fig. A)  
Resistance = 3MΩ—5.2MΩ

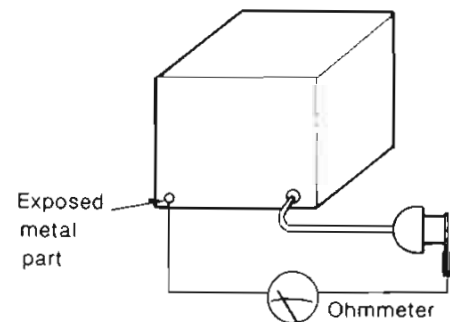

(Fig. B)  
Resistance = Approx ∞

4. If the measurement is outside the specified limits, there is a possibility of a shock hazard. The equipment should be repaired and rechecked before it is returned to the customer.

**FM/AM Stereo Tuner (ST-Z200)**  
**FM/MW/LW Stereo Tuner (ST-Z200L)**

**ST-Z200/ST-Z200L**

- This booklet includes the specifications and adjustment of Model ST-Z200/ST-Z200L (Order No. HAD84052772C9) written in German, French and Spanish.
- File this booklet together with the service manual of Model ST-Z200/ST-Z200L.
- Dieses Büchlein umfaßt die technischen Daten und Justierungsanleitungen von Modell ST-Z200/ST-Z200L (Bestell Nr. HAD84052772C9) in den Sprachen Deutsch, Französisch und Spanisch.
- Bewahren Sie dieses Büchlein zusammen mit dem Service-Handbuch von Modell ST-Z200/ST-Z200L.
- Cette brochure comprend les spécifications et la mise au point du Modèle ST-Z200/ST-Z200L (N° d'Ordre HAD84052772C9) écrites en allemand, en français et en espagnol.
- Classer cette brochure en meme temps qu'avec le manuel de service du Modele ST-Z200/ST-Z200L.
- Este librito incluye las especificaciones y ajuste de Modelo ST-Z200/ST-Z200L (Pedido N° HAD84052772C9) escritas en alemán, francés y español.
- Guardar este librito juntamente con el manual servicio de Modelo ST-Z200/ST-Z200L.

**DEUTSCH**

**TECHNISCHE DATEN**

(Spezifikationen Können infolge von Verbesserungen ohne Ankündigung geändert werden.)

**(DIN 45 500)**

**UKW-TUNERTEIL**

Wellenbereich	88 ~ 108 MHz
Eingangsempfindlichkeit	0.95 μV (nutzbar nach IHF)
S/R 30 dB	1.0 μV (75 Ω)
S/R 26 dB	0.9 μV (75 Ω)
S/R 20 dB	0.8 μV (75 Ω)
Stereoschalterschwelle bei 46 dB nach IHF	22 μV/75 Ω
Gesamtklirrfaktor	
Mono	0,15%
Stereo	0,3%
Geräuschabstand	
Mono	70 dB (78 dB nach IHF)
Stereo	65 dB (70 dB nach IHF)
Frequenzgang	20 Hz ~ 15 kHz (+0,5 dB ~ -1,5 dB)
Trennschärfe bei Störsender (±400 kHz)	65 dB
Einfangverhältnis	1,0 dB
Spiegelfrequenz-Dämpfung bei 98 MHz	40 dB
ZF-Dämpfung bei 98 MHz	70 dB
Ansprechdämpfung auf Nebenfrequenzen bei 98 MHz	70 dB
MW-Unterdrückung	50 dB
Übersprechdämpfung	
1 kHz	40 dB
10 kHz	30 dB
Trägerrest	
19 kHz	-30 dB (-35 dB nach IHF)
38 kHz	-45 dB (-50 dB nach IHF)
Kanalabweichung (250 Hz ~ 6300 Hz)	±1,5 dB
Begrenzereinsatz	1,2 μV
Bandbreite	
ZF-Verstärker	180 kHz
UKW-Demodulator	1000 kHz
Antennenanschluß	75 Ω (unsymmetrisch)

**MW-TUNERTEIL (ST-Z200)**

Wellenbereiche	525 ~ 1605 kHz
Eingangsempfindlichkeit (S/R 20 dB)	20 μV, 300 μV/m
Trennschärfe (±10 kHz)	27 dB
Spiegelfrequenz-Dämpfung bei 1000 kHz	40 dB
ZF-Dämpfung bei 1000 kHz	65 dB

**MW/LW-TUNERTEIL (ST-Z200L)**

Wellenbereiche	
MW	525 ~ 1605 kHz
LW	145 ~ 350 kHz
Eingangsempfindlichkeit (S/R 20 dB)	
MW	20 μV, 300 μV/m
LW	50 μV
Trennschärfe	
MW (±10 kHz)	27 dB
LW (250 kHz)	35 dB
Spiegelfrequenz-Dämpfung	
MW	40 dB (1000 kHz)
LW	40 dB (250 kHz)
ZF-Dämpfung	
MW	65 dB (1000 kHz)
LW	40 dB (250 kHz)

**ALLGEMEINE DATEN**

Ausgangsspannung	0,3 V (0,6V IHF)
Leistungsaufnahme	6W
Netzspannung	
Für Kontinentaleuropa	Wechselstrom 50 Hz/60 Hz, 220V
Für andere Länder	Wechselstrom 50 Hz/60 Hz, 110V/120V/220V/240V
Abmessungen (B×H×T)	430 × 53 × 242 mm
Gewicht	2,4 kg



**MESSUNGEN UND JUSTIERUNGEN**

- Beim Abgleichen der hohen Frequenz ist zuerst die Spule abzugleichen (Abgleich der niedrigen Frequenz), und dann allmählich der lose Trimmer anzuziehen, um den Abgleich der hohen Frequenz vorzunehmen. Für den Abgleich der Oszillationsspule und des ZFT ist ein nichtmetallischer Schraubenzieher zu verwenden.
- Den Anzeiger vor dem Abgleich unbedingt auf den Startpunkt einstellen. (Siehe Abb. 2)

**Stellungen und zu benutzende Geräte**

- |  |   |
|--|---|
| 1. Elektronische Voltmeter für Wechsel- und Gleichstrom (VTVM).        | 7. FM Muting/Mode Schalter, . . . . . off/FM mono.  |
| 2. AM (MW)-Meßsender (AM-SG)   | 8. Die Netzspannung auf ihren Sollwert einstellen.  |
| 3. UKW-Meßsender (FM-SG)   | 9. Der Ausgang des Meßsenders darf nicht höher sein als unbedingt notwendig für eine gute ablesung. |
| 4. Oszilloskop   |   |
| 5. Signalfrequenzmesser (meßbar für 19kHz und 108MHz).                 |   |
| 6. Bereichsschalter . . . . . AM (MW/LW Abgleich)<br>FM (UKW Abgleich) |   |

**Vorbereitung des UKW-Meßoszillators (UKW-MO)**

- Die Normal-Eingangsleistung dieses Gerätes beträgt 60 dB (1 mV), 400 Hz, 100% Modulation. (Wegen der Dämpfung bei Verwendung von Koaxialkabeln, muß die MO-Ausgangsleistung 6 dB oder mehr (IHF) betragen; d. h. wenn die Eingangsleistung 60 dB beträgt, muß der MO-Ausgang 66 dB betragen.)

Nr.	AM/UKW MESSENDER		SKALENZEIGEREIN-STELLUNG DES TUNER	ANZEIGEGERÄT (Röhrenvoltmeter oder Oszillograph)	ABGLEICHSPUNKTE	BEMERKUNGEN
	ANSCHLUSS	FREQUENZ				
<b>AM (MW/LW)-ZF-ABGLEICH</b>						
1	AM-MO über 200 pF-Kondensator an den AM-Antennenanschluß anschließen, wie in Abb. 3 gezeigt. (Starker Eingang.)	450kHz (400 Hz Modulat., 30%)	Kein Empfang	Wechselstrom Röhrenvoltmeter oder Oszillograph über den Ausgang "OUTPUT" schließen.	T201 (AM. IFT)	Die Eingangsfrequenz und die Einstellungspunkte so adjustieren, daß der Ausgang den maximalen Wert erreicht.
<b>ST-Z200 MW-HF-ABGLEICH</b> * Bandwahlschalter in die "MW"-position stellen.						
2	AM-MO über 200 pF-Kondensator an den AM-Antennenanschluß anschließen, wie in Abb. 3 gezeigt. (Schwacher Eingang.)	600kHz (400 Hz Modulat., 30%)	600kHz	Wechselstrom Röhrenvoltmeter oder Oszillograph über den Ausgang "OUTPUT" schließen.	L202 (MW OSC. Spule) L203 (MW ANT. Spule)	• Auf max. Ausgang abgleichen.
3		1500kHz (400 Hz Modulat., 30%)	1500kHz	Wechselstrom Röhrenvoltmeter oder Oszillograph über den Ausgang "OUTPUT" schließen.	CT201 (MW OSC. Trimmer) CT202 (MW ANT. Trimmer)	• Auf max. Ausgang abgleichen. • Schritt (2) und (3) sind zu wiederholen.
<b>ST-Z200L LW-HF-ABGLEICH</b> * Bandwahlschalter in die "LW"-position stellen.						
4	AM-MO über 200 pF-Kondensator an den AM-Antennenanschluß anschließen, wie in Abb. 3 gezeigt. (Schwacher Eingang.)	145 kHz (400 Hz Modulat., 30%)	145 kHz	Wechselstrom Röhrenvoltmeter oder Oszillograph über den Ausgang "OUTPUT" schließen.	L251 (LW OSC. Spule) L252 (LW ANT. Spule)	• Auf max. Ausgang abgleichen.
5		350 kHz (400 Hz Modulat., 30%)	350 kHz	Wechselstrom Röhrenvoltmeter oder Oszillograph über den Ausgang "OUTPUT" schließen.	CT251 (LW OSC. Trimmer) CT252 (LW ANT. Trimmer)	• Auf max. Ausgang abgleichen. • Schritt (4) und (5) sind zu wiederholen.
<b>UKW-ZF-ABGLEICH</b>						
6		Kein Signal	Kein Empfang	Ein Gleichstromröhrenvoltmeter zwischen TP101 (+) und TP102 (-) über eine Drosselspule verbinden (siehe Abb. 4)	T101 (Diskriminator IFT)	• FM muting/FM mode Schalter, auf "on/FM auto" stellen. • Den Kern von T101 so justieren, daß die gemessene Spannung im signallosen Modus 0mV im 300mV Bereich beträgt.
<b>UKW-HF-ABGLEICH</b>						
7	Verbinden FM-SG zu FM Antennende (Schwacher Input).	87,5MHz (400 Hz Modulat., 100%) Schwacher Eingang	87,5MHz (Frequenzmin.)	Oszillograph über den Ausgang "OUTPUT" schließen.	L4 (OSC. Spule)	• Einen schwachen Eingang geben, bei dem Geräusch in der Ausgangswellenform enthalten wird. • So einstellen, daß die Ausgangswellenform vertikal symmetrisch wird. (Abb. 5) • Bei Einstellung von (7), (8) und (9) wiederholen, bis die Frequenz mit der Skala übereinstimmt.
8		90MHz (400 Hz Modulat., 100%) Schwacher Eingang	90MHz	Oszillograph über den Ausgang "OUTPUT" schließen.	L2 (RF Det. Spule)	
9		106MHz (400 Hz Modulat., 100%) Schwacher Eingang	106MHz	Oszillograph über den Ausgang "OUTPUT" schließen.	CT1 (OSC. Trimmer)	

UKW-STEREO-DEKODER-ABGLEICH	
UNTER VERWENDUNG EINES ZÄHLERS	ALTERNATIV-MEß METHODE
1. Unmoduliertes Mono-Signal 100MHz in das Gerät speisen. (Vgl. Abb. 6)	1. Stereosignal entweder von einem Stereogenerator, oder einem Sender einspeisen.
2. FM muting/mode-Schalter auf "on/FM auto" stellen.	2. VR301 so einstellen, bis die Stereolampe auf leuchtet.
3. Zähler über einen Widerstand 100k ohm an TP301 schließen.	Schleifer von VR301 sichern, wie in Abb. 7 gezeigt.
4. VR301 auf 19kHz ± 30 Hz einstellen.	

**FRANÇAIS**

**CARACTERISTIQUES** (Sujet à changement sans preavis)

<p><b>(DIN 45 500)</b></p> <p>■ SECTION SYNTONISATEUR FM</p> <p>Gamme de fréquence 88~108 MHz</p> <p>Sensibilité 0,95 µV (IHF utilisable)</p> <p>S/B 30 dB 1,0 µV (75Q)</p> <p>S/B 26 dB 0,9 µV (75Q)</p> <p>S/B 20 dB 0,8 µV (75Q)</p> <p>Sensibilité stéréo au seuil de 46 dB, IHF 22 µV/75Q</p> <p>Distorsion harmonique totale MONO 0,15%</p> <p>STEREO 0,3%</p> <p>Signal/Bruit MONO 70 dB (78 dB, IHF)</p> <p>STEREO 65 dB (70 dB, IHF)</p> <p>Réponse de fréquence 20 Hz~15 kHz, +0,5 dB~ -1,5 dB</p> <p>Sélectivité alternée par canal (±400 kHz) 65 dB</p> <p>Taux de capture 1,0 dB</p> <p>Rejection d'image à 98 MHz 40 dB</p> <p>Rejection FI à 98 MHz 70 dB</p> <p>Rejection de réponse parasite à 98 MHz 70 dB</p> <p>Suppression AM 50 dB</p> <p>Séparation stéréophonique 1 kHz 40 dB</p> <p>10 kHz 30 dB</p> <p>Fuite de porteuse 19 kHz -30 dB (-35 dB, IHF)</p> <p>38 kHz -45 dB (-50 dB, IHF)</p> <p>Equilibrage de canaux (250 Hz~6,300 Hz) ±1,5 dB</p> <p>Point de limite 1,2 µV</p> <p>Largeur de bande Amplificateur FI 180 kHz</p> <p>Démodulateur FM 1000 kHz</p> <p>Bornes d'antenne 75Ω (asymétrique)</p>	<p>■ SECTION SYNTONISATEUR AM (ST-Z200)</p> <p>Gamme de fréquence 525~1605 kHz</p> <p>Sensibilité (S/B 20 dB) 20 µV, 300 µV/m</p> <p>Sélectivité (±10 kHz) 27 dB</p> <p>Réjection d'image à 1,000 kHz 40 dB</p> <p>Réjection FI à 1,000 kHz 65 dB</p> <p>■ SECTION SYNTONISATEUR AM (ST-Z200L)</p> <p>Gamme de fréquence PO (MW) 525~1605 kHz</p> <p>GO (LW) 145~350 kHz</p> <p>Sensibilité (S/B 20 dB) PO (MW) 20 µV, 300 µV/m</p> <p>GO (LW) 50 µV</p> <p>Sélectivité PO (MW) (±10 kHz) 27 dB</p> <p>GO (LW) (250 kHz) 35 dB</p> <p>Réjection d'image PO (MW) 40 dB (1000 kHz)</p> <p>GO (LW) 40 dB (250 kHz)</p> <p>Réjection FI PO (MW) 65 dB (1000 kHz)</p> <p>GO (LW) 40 dB (250 kHz)</p> <p>■ DIVERS</p> <p>Tension de sortie 0,3 V (0,6V IHF)</p> <p>Consommation Alimentation Pour l'Europe CA 50 Hz/60 Hz, 220V</p> <p>Autres CA 50 Hz/60 Hz, 110V/120V/220V/240V</p> <p>Dimensions (LxHxPr) 430 x 53 x 242 mm</p> <p>Poids 2,4 kg</p>
---	--

**MESURAGES ET RÉGLAGES**

- Lorsque l'on règle la haute fréquence, régler tout d'abord la bobine (mise au point de la fréquence inférieure), puis graduellement resserrer le condensateur d'appoint desserré pour effectuer le réglage de la haute fréquence. Utiliser un tournevis non-métallique lorsque l'on règle la bobine oscillatrice et IFT (transformateur de fréquence intermédiaire).
- S'assurer que l'indicateur est réglé sur le point de départ avant d'effectuer la mise au point. (Voir Fig. 2)

<p>• Réglage et équipement utilisé</p> <ol style="list-style-type: none"> <li>1. Voltmètres électronique de courant alternatif et de courant continu (VTVM).</li> <li>2. Générateur du signal AM (AM-SG).</li> <li>3. Générateur du signal FM (FM-SG).</li> <li>4. Oszilloscope</li> <li>5. Compteur de fréquence (19kHz et 108MHz mesurable).</li> <li>6. Sélecteur de gamme, . . . . . AM (Alignement MW/LW) FM (Alignement FM)</li> </ol>	<ol style="list-style-type: none"> <li>7. Commutateur de silencieux/mode, . . . . . off/FM mono.</li> <li>8. Conserver la tension du secteur à la tension nominale.</li> <li>9. Le signal du générateur ne doit pas être plus élevé qu'il n'est nécessaire à obtenir une lecture en sortie.</li> </ol>
--	--

Préparatif du générateur de signaux à Modulation de Fréquence (FM-SG)						
1. L'entrée normale de l'appareil est de 60 dB (1 mV), 400 Hz, modulation de 100%. (Du fait de l'atténuation, utiliser des câbles coaxiaux. La sortie du générateur de signaux devra être de plus de 60 dB (IHF). C'est-à-dire que lorsque l'entrée est de 60 dB, la sortie du générateur de signaux devra être de 66 dB.)						
BRANCHEMENT	FREQUENCE	AIGUILLE SUR LE CADRAN	INDICATEUR (VOLT-METRE ELECTRONIQUE OSCILLOSCOPE)	POINTS DE REGLAGE	OBSERVATIONS	
<b>RÉGLAGE DE FI-AM</b>						
1	Raccorder le générateur de signaux AM (modulation d'amplitude) à la borne d'antenne AM par l'intermédiaire d'un condensateur de 200 pF, en se référant à la Fig. 3. (Entrée sous pulsante)	450kHz (modulé à 30% par 400 Hz)	Point sans signal	C.A. voltmètre électronique ou oscilloscope sur prise de sortie de l'appareil.	T201 (AM transfo FI)	• Régler la fréquence d'entrée et les points de réglage de telle sorte que la sortie devienne maximale.
<b>ST-Z200 RÉGLAGE DE RF-MW (PO)</b> * Régler le commutateur de gammes d'ondes sur la position "MW".						
2	Raccorder le générateur de signaux AM (modulation d'amplitude) à la borne d'antenne AM par l'intermédiaire d'un condensateur de 200 pF, en se référant à la Fig. 3. (Entrée faible)	600kHz (modulé à 30% par 400 Hz)	600kHz	C.A. voltmètre électronique ou oscilloscope sur prise de sortie de l'appareil.	L202 (Bobine OSC MW) L203 (Bobine ANT MW)	• Régler au maximum de signal de sortie.
3		1500kHz (modulé à 30% par 400 Hz)	1500kHz	C.A. voltmètre électronique ou oscilloscope sur prise de sortie de l'appareil.	CT201 (Trimmer OSC MW) CT202 (Trimmer ANT MW)	• Régler au maximum de signal de sortie. • Recommencez les étapes (2) et (3)
<b>ST-Z200L RÉGLAGE DE RF-LW (GO)</b> * Régler le commutateur de gammes d'ondes sur la position "LW".						
4	Raccorder le générateur de signaux AM (modulation d'amplitude) à la borne d'antenne AM par l'intermédiaire d'un condensateur de 200 pF, en se référant à la Fig. 3. (Entrée faible)	145 kHz (modulé à 30% par 400 Hz)	145 kHz	C.A. voltmètre électronique ou oscilloscope sur prise de sortie de l'appareil.	L251 (Bobine OSC LW) L252 (Bobine ANT LW)	• Régler au maximum de signal de sortie.
5		350 kHz (modulé à 30% par 400 Hz)	350 kHz	C.A. voltmètre électronique ou oscilloscope sur prise de sortie de l'appareil.	CT251 (Trimmer OSC LW) CT252 (Trimmer ANT LW)	• Régler au maximum de signal de sortie. • Recommencez les étapes (4) et (5).
<b>RÉGLAGE DE FI-FM</b>						
6		Sans signal	Point sans signal	Brancher le voltmètre électronique à C.C. aux bornes TP101 (+) TP102 (-). (Voir la fig. 4)	T101 (Transfo FI discri.)	• Commutateur de silencieux sur "on/FM auto". • Régler le noyau T101 de telle sorte que le voltage mesuré dans le mode sans signal, soit de 0mV dans la gamme des 300mV.
<b>RÉGLAGE DE RF-FM</b>						
7	Raccorder le Générateur de Fréquences FM à la Borne d'antenne (Entrée Faible).	90 MHz (modulé à 100% par 400 Hz) Entrée faible	90 MHz	Oscilloscope sur prise de sortie du tuner.	L4 (bobine OSC) L2 (bobine DET RF)	• Appliquer une entrée faible de telle sorte que le parasite soit compris dans la forme de l'onde de sortie. • Faire le réglage de telle sorte que la forme de l'onde de sortie soit verticalement symétrique. (Voir fig. 5)
8		106 MHz (modulé à 100% par 400 Hz) Entrée faible	106 MHz	Oscilloscope sur prise de sortie du tuner.	CT1 (trimmer OSC)	• Refaire les réglages (7) et (8) jusqu'à ce que la fréquence corresponde correctement avec l'échelle du cadran.
<b>RÉGLAGE PILOTE MULTIPLEX FM</b>						
AVEC UN ERÉQUENCÉMÈTRE			PAR UN OUTRE SYSTÈME			
1. Signet mono 100MHz non modulé appliqué à l'appareil. (Voir Fig. 6)						
2. Commutateur de silencieux sur "on/FM auto".						
3. Branchez le fréquencimètre sur TP301 à travers une						
4. Réglez VR301 sur 19kHz ± 30 Hz.						
1. Appliquez à l'appareil un signal stéréo provenant d'un générateur ou de la réception d'un émetteur.						
2. Réglez VR301 jusqu'à ce que l'indicateur de stéréophonie s'allume. Collez le curseur le VR301 comme indiqué sur la fig. 7.						



ESPAÑOL

■ ESPECIFICACIONES

Estas especificaciones están sujetas a cualquier cambio sin previo aviso.

<b>(DIN 45 500)</b>		<b>■ SECCION PARA SINTONIZADOR AM (ST-Z200)</b>	
<b>■ SECCION PARA SINTONIZADOR FM</b>		<b>Gama de frecuencias</b> 525~1605 kHz	
Gama de frecuencias	88~108 MHz	<b>Sensibilidad (Relación de señal a ruido de 20 dB)</b>	20 µV, 300 µV/m
Sensibilidad	0,95 µV (IHF, utilizable)	<b>Selectividad (±10 kHz)</b>	27 dB
Señal a ruido 30 dB	1,0 µV (75Ω)	<b>Rechazo de imagen a 1.000 kHz</b>	40 dB
Señal a ruido 26 dB	0,9 µV (75Ω)	<b>Rechazo de F.I. a 1.000 kHz</b>	65 dB
Señal a ruido 20 dB	0,8 µV (75Ω)	<b>■ SECCION PARA SINTONIZADOR AM (ST-Z200L)</b>	
<b>Sensibilidad de acallamiento estéreo de 46 dB IHF 22 µV/75Ω</b>		<b>Gama de frecuencias</b>	525~1605 kHz
<b>Distorsión armónica total MONO. (MONO)</b>	0,15%	<b>OM (MW)</b>	145~350 kHz
<b>ESTEREO (STEREO)</b>	0,3%	<b>OL (LW)</b>	145~350 kHz
<b>Relación de señal a ruido MONO. (MONO)</b>	70 dB (78 dB, IHF)	<b>Sensibilidad (Relación de señal a ruido de 20 dB)</b>	20 µV, 300 µV/m
<b>ESTEREO (STEREO)</b>	65 dB (70 dB, IHF)	<b>OM (MW)</b>	50 µV
<b>Respuesta de frecuencia</b>	20 Hz~15 kHz, +0,5 dB~-1,5 dB	<b>OL (LW)</b>	50 µV
<b>Selectividad alternada de canal (±400 kHz)</b>	65 dB	<b>Selectividad</b>	
<b>Relación de captura</b>	1,0 dB	<b>OM (MW) (±10 kHz)</b>	27 dB
<b>Rechazo de imagen a 98 MHz</b>	40 dB	<b>OL (LW) (250 kHz)</b>	35 dB
<b>Rechazo de F.I. a 98 MHz</b>	70 dB	<b>Rechazo de imagen OM (MW)</b>	40 dB (1000 kHz)
<b>Rechazo de respuesta espuria a 98 MHz</b>	70 dB	<b>OL (LW)</b>	40 dB (250 kHz)
<b>Supresión AM</b>	50 dB	<b>Rechazo de F.I. OM (MW)</b>	65 dB (1000 kHz)
<b>Separación estereofónica</b>		<b>OL (LW)</b>	40 dB (250 kHz)
1 kHz	40 dB	<b>■ GENERAL</b>	
10 kHz	30 dB	<b>Voltaje de salida</b>	0,3V (0,6V IHF)
<b>Fuga de onda portadora</b>		<b>Consumo de energía</b>	6W
19 kHz	-30 dB (-35 dB, IHF)	<b>Alimentación de energía</b>	
38 kHz	-45 dB (-50 dB, IHF)	Para Europa continental	CA 50 Hz/60 Hz, 220V
<b>Equilibrio de canales 250 Hz~6 300 Hz</b>	±1,5 dB	Para otros países	CA 50 Hz/60 Hz, 110V/120V/220V/240V
<b>Punto de limite</b>	1,2 µV	<b>Dimensiones (An.XAl.XProf.)</b>	430 x 53 x 242 mm
<b>Ancho de banda</b>		<b>Peso</b>	2,4 kg
Amplificador FI	180 kHz		
Demodulador FM	1000 kHz		
<b>Bornes de antena</b>	75Ω (no equilibrado)		

■ MEDICIONES Y AJUSTE

- Al ajustar la alta frecuencia, primero ajustar la bobina (ajuste de frecuencia inferior) y entonces, gradualmente, apretar el trimer flojo para efectuar el ajuste de alta frecuencia. Utilizar un destornillador no metálico al ajustar la bobina de oscilación y IFT (transformador de frecuencia intermedia).
- Asegurarse de que el indicador está puesto en el punto de arranque antes del ajuste. (Véase la Fig. 2)

<b>• Puesta y Uso de equipo</b>	
1. Voltímetros electrónicos de CA y CC (VTVM).	7. Interruptor silenciador/modalidad FM . . . . . off/mono.
2. Generador de señales AM (AM-SG).	8. Mantener voltaje de línea a voltaje nominal.
3. Generador de señales FM (FM, SG).	9. La salida de generador de señales no debe ser mayor que la necesaria para obtener una lectura de salida.
4. Osciloscopio.	
5. Frecuencímetro (19kHz y 108MHz medibles).	
6. Selector de bande . . . . . {AM (Ajuste de MW/LW) {FM (Ajuste de FM)	

**• Preparación de generador de señales de FM (FM-SG)**  
La entrada standard del aparato es de 60 dB (1 mV), modulación 100%, 400 Hz (Debido a atenuación, usando cables coaxiales. La salida de GS ha de ser de 6 dB más (IHF). Eso es cuando 60 dB de entrada, la salida de GS ha de ser de 66 dB.

GENERADOR DE SEÑALES AM/FM		PUESTA DE CUADRANTE	PREPARACIONES	PIEZAS AJUSTADAS	PROCEDIMIENTO DE AJUSTE
CONEXION	FRECUENCIA				
<b>ST-Z200/ST-Z200L AJUSTE IF-MW (OM)-LW (OL)</b>					
1 2	Conectar SG-AM a terminal de antena AM a través de capacitor de 200 pF, refiriendo a la Fig. 3. (Entrada potente.)	450kHz (Mod. 30% con 400Hz)	Punto de no interferencia.	Conectar VTVM de CA u osciloscopio a terminales "OUTPUT" del aparato.	T201 (IFT AM)

GENERADOR DE SEÑALES AM/FM		PUESTA DE CUADRANTE	PREPARACIONES	PIEZAS AJUSTADAS	PROCEDIMIENTO DE AJUSTE
CONEXION	FRECUENCIA				
<b>ST-Z200 AJUSTE RF-MW (OM) • Selector de band "MW"</b>					
2 3	Conectar SG-AM a terminal de antena AM a través de capacitor de 200 pF, refiriendo a la Fig. 3. (Entrada débil.)	600kHz (Mod. 30% con 400Hz) 1500kHz (Mod 30% con 400Hz)	600kHz 1500kHz	Conectar VTVM de CA u osciloscopio a terminales "OUTPUT" del aparato.	L202 (Bobina OSC MW) L203 (Bobina ANT MW) CT201 (Trimer de OSC MW) CT202 (Trimer de ANTMW)
<b>ST-Z200L AJUSTE RF-LW (OL) • Selector de band "LW"</b>					
4 5	Conectar SG-AM a terminal de antena AM a través de capacitor de 200 pF, refiriendo a la Fig. 3. (Entrada débil.)	145 kHz (Mod. 30% con 400 Hz) 350 kHz (Mod. 30% con 400 Hz)	145 kHz 350 kHz	Conectar VTVM de CA u osciloscopio a terminales de "OUTPUT".	L251 (Bobina OSC LW) L252 (Bobina ANT LW) CT251 (Trimer de OSC LW) CT252 (Trimer de ANT LW)
<b>AJUSTE IF-FM</b>					
6		No señal.	Punto de no interferencia.	Conectar VTVM CC entre terminal TP101 (+) y TP102 (-) a través de bobina de choque. (Véase la Fig. 8).	T101 (Discri. IFT)
<b>AJUSTE RF-FM</b>					
7 8	Conectar FM-SG a terminal de antena FM (entrada débil)	90MHz (Mod. 100% con 400Hz) Entrada débil. 106MHz (Mod. 100% con 400Hz) Entrada débil.	90MHz 106MHz	Conectar osciloscopio a terminales "OUTPUT" del aparato.	L4 (Bobina OSC) L2 (Bobina DET RF) CT1 (Trimer OSC)
<b>AJUSTE DE V.C.O MPX de FM</b>					
<b>USANDO UN FRECUENCIMETRO</b>			<b>USANDO SISTEMA ALTERNATIVO</b>		
1. Señal mono no modulada de 100MHz 60 dB aplicada (Véase la Fig. 6) al aparato.			1. Aplicar señal estereofónica de generador o estación estereofónica a sintonizador.		
2. Interruptor de modalidad/silenciador FM a "on/auto FM".			2. Ajustar VR301 hasta que indicador estereofónico se ilumina.		
3. Conectar frecuencímetro a TP301 a través de resistor (100kΩ).			Brazo de cemento de VR301 como se muestra en la Fig. 7.		
4. Ajustar VR301 a 19kHz ± 30Hz.					

## LOCATION OF CONTROLS

**ST-Z200**

Power  
( ■ stand by, ▲ on)

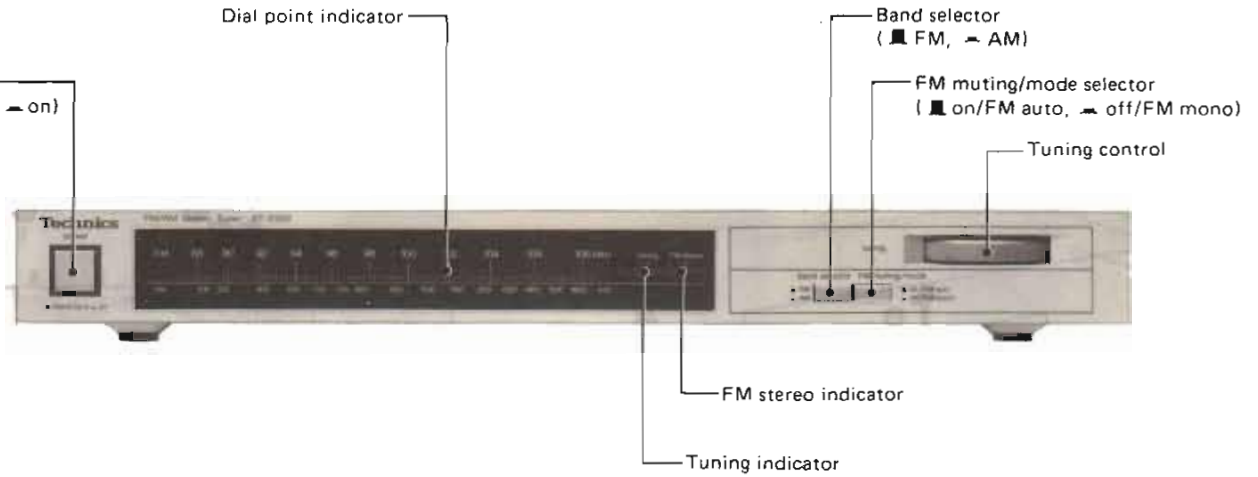

**ST-Z200L**

Power  
( ■ stand by, ▲ on)

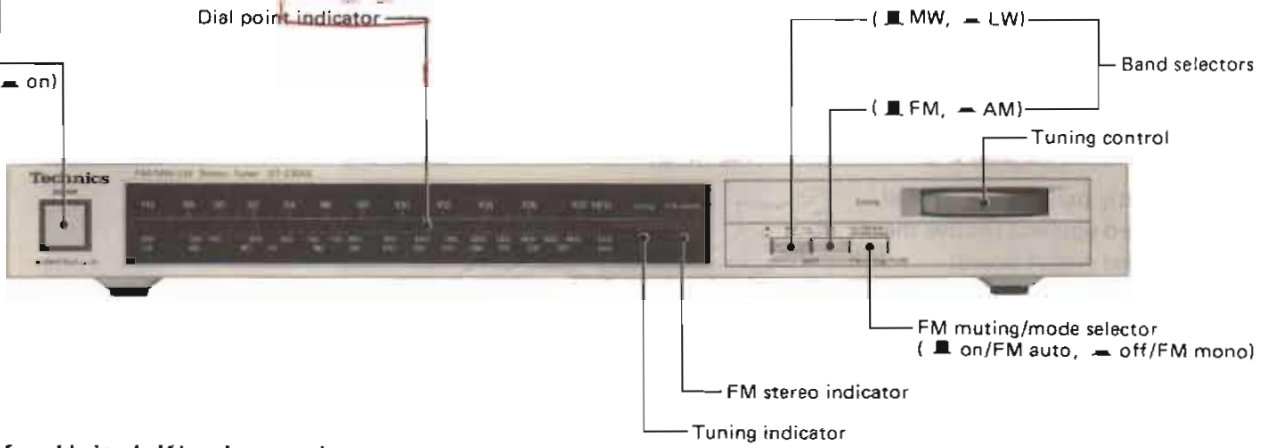

### ● Product for United Kingdom only

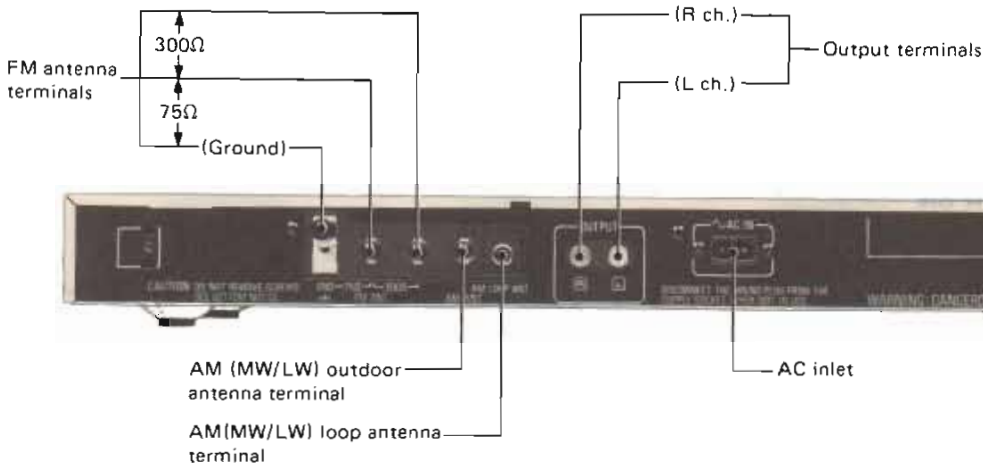

### ● Others

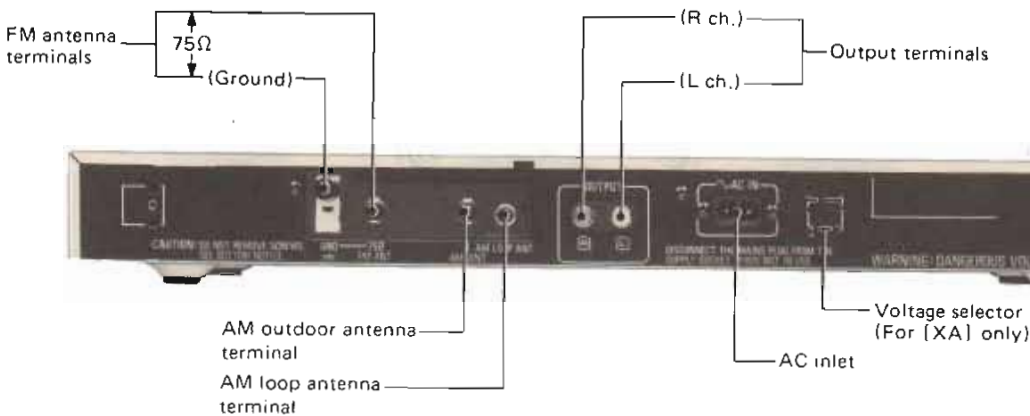

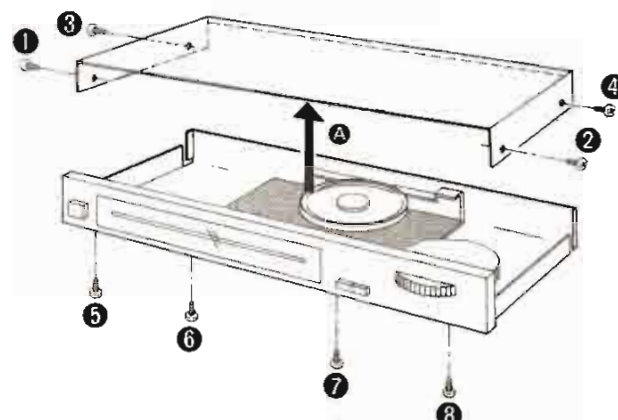
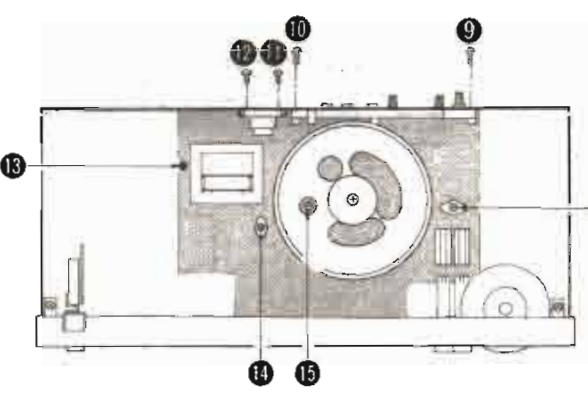
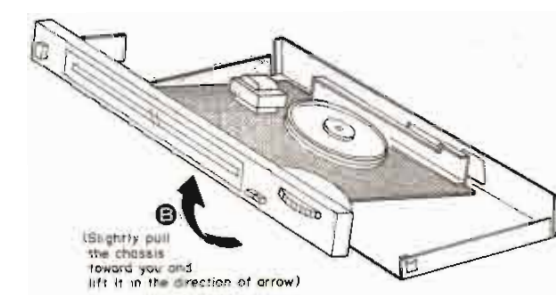

DISASSEMBLY INSTRUCTIONS

Ref. No.	How to remove the printed circuit board
1	<p>① Remove the 8 setscrews.</p>  <p>② Remove the 8 setscrews.</p>  <p>③ Slightly pull the front panel toward you and remove the printed circuit board.</p>  <p>(Slightly pull the chassis toward you and lift it in the direction of arrow)</p>

DIAL CORD INSTALLATION GUIDE

When setting the cord, follow the procedure given below.

- The cord should be at least 150 cm long.
  - Completely turn the tuning gang (variable capacitor) counterclockwise. (Variable condenser capacity: max. Frequency: min.).
  - Make a knot at the cord and as shown in Fig. 1.
  - Set the spring to the knot, and set the cord in the order of 1 ~ 10.
- Note:** At step 7, pull the cord strongly, slacken the spring up to the mark of the drum, then go to step 8 ~ 10 to set the cord.
- Fix the cord terminal with adhesive.
  - Cut off the cord about 5 mm at its either end.

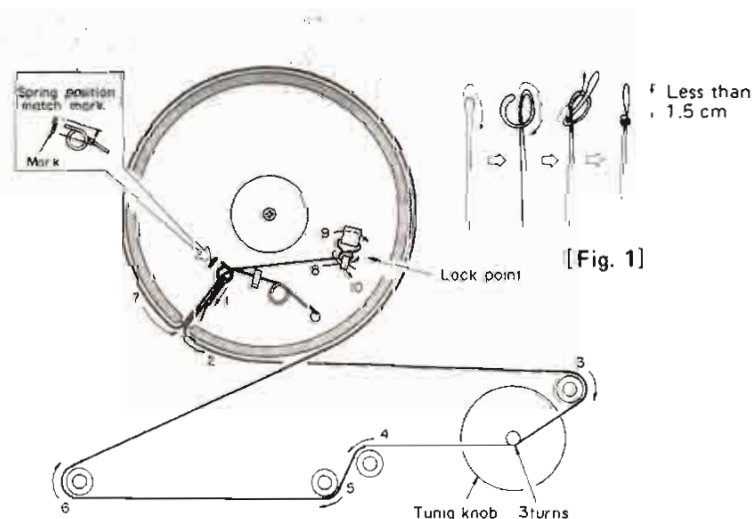

MEASUREMENTS AND ADJUSTMENTS

- When adjusting the high frequency, first adjust the coil (lower frequency adjustment) and then gradually tighten the loose trimmer to make the high frequency adjustment. Use a non-metallic screwdriver when adjusting the OSC coil and IFT.
- Make sure that the indicator is set at the start point before the adjustment. (See Fig. 2)

Setting and Equipment used	Preparation of FM signal generator (FM-SG)
<ol style="list-style-type: none"> <li>AC and DC electronic voltmeters (VTVM)</li> <li>AM signal generator (AM-SG)</li> <li>FM signal generator (FM-SG)</li> <li>Oscilloscope</li> <li>Frequency counter (19 kHz and 108 MHz measurable)</li> <li>Band selector switch . . . . . AM (MW/LW adjustment) FM (FM adjustment)</li> <li>FM muting mode switch . . . . . off/FM mono</li> <li>Maintain line voltage at rated voltage.</li> <li>Output of signal generator should be no higher than necessary to obtain an output reading.</li> </ol>	<ol style="list-style-type: none"> <li>The standard input of the set is 60 dB (1 mV), 400 Hz, 100% modulation (Because of attenuation, using coaxial cables, SG output must be 6 dB plus (IHF). That is when input 60 dB, SG output to be 66 dB.)</li> </ol>

Step No.	AM/FM GENERATOR		DIAL SETTING	INDICATOR (VTVM or SCOPE)	ADJUSTMENT POINTS	REMARKS
	CONNECTION	FREQUENCY				
<b>AM-IF ADJUSTMENT</b>						
1	Connect AM-SG to AM antenna terminal through 200pF capacitor referring to Fig. 3. (Powerful input)	450 kHz (30% Mod. with 400 Hz)	Point of non-interference	Connect AC VTVM or scope to "OUTPUT" terminals.	T201 (AM IFT)	Adjust the input frequency and adjustment points so that the output becomes maximum.
<b>AM (MW) - RF ADJUSTMENT</b> * Set band selector to "AM (MW)" position.						
2	Connect AM-SG to AM antenna terminal through 200pF capacitor referring to Fig. 3. (Weak input)	600 kHz (30% Mod. with 400 Hz)	600 kHz	Connect AC VTVM or scope to "OUTPUT" terminals.	L202 (MW OSC Coil) L203 (MW ANT Coil)	Adjust for maximum output.
3		1500 kHz (30% Mod. with 400 Hz)	1500 kHz	Connect AC VTVM or scope to "OUTPUT" terminals	CT201 (MW OSC Trimmer) CT202 (MW ANT Trimmer)	Adjust for maximum output. Repeat steps (2) and (3).
<b>ST-Z200L AM (LW) - RF ADJUSTMENT</b> *Set band selector to "LW" position.						
4	Connect AM-SG to AM antenna terminal through 200pF capacitor referring to Fig. 3. (Weak input)	145 kHz (30% Mod. with 400 Hz)	145 kHz	Connect AC VTVM or scope to "OUTPUT" terminals.	L251 (LW OSC Coil) L252 (LW ANT Coil)	Adjust for maximum output.
5		350 kHz (30% Mod. with 400 Hz)	350 kHz	Connect AC VTVM or scope to "OUTPUT" terminals.	CT251 (LW OSC Trimmer) CT252 (LW ANT Trimmer)	Adjust for maximum output. Repeat steps (4) and (5).
<b>FM-IF ADJUSTMENT</b>						
6	No-Signal	No-Signal	Point of non-interference	Connect DC VTVM between TP101 and TP102 through choke coil. (Refer to Fig. 4)	T101 (Discr. IFT)	FM muting/mode switch to "on/FM auto" position. Adjust T101 core so that voltage measured in signal mode is 0 mV in 300 mV range.
<b>FM-RF ADJUSTMENT</b>						
7	Connect FM-SG to FM antenna terminal. (Weak input)	90 MHz (100% Mod. with 400 Hz)	90 MHz	Connect scope to "OUTPUT" terminal.	L4 (OSC Coil) L2 (RF DET. Coil)	Add weak input so that noise is included in the output wave form. Make the adjustment so that the output wave form is vertically symmetrical. (Fig. 5)
8		106 MHz (100% Mod. with 400 Hz)	106 MHz	Connect scope to "OUTPUT" terminal.	CT1 (OSC Trimmer)	Repeat the steps (7) and (8) until the frequency correctly matches the dial scale.
<b>FM MPX V.C.O. ADJUSTMENT</b>						
<b>USING A FREQUENCY COUNTER</b>				<b>USING ALTERNATE SYSTEM</b>		
9	<ol style="list-style-type: none"> <li>100 MHz, 60 dB Non-modulated mono signal applied to set. (Refer to Fig. 6)</li> <li>FM muting/mode switch to "on/FM auto" position.</li> <li>Connect frequency counter to TP301 through resistor (100kΩ).</li> <li>Adjust VR301 to 19 kHz ± 30 Hz.</li> </ol>			<ol style="list-style-type: none"> <li>Apply stereo signal from generator or stereo station to tuner.</li> <li>Adjust VR301 until stereo indicator lights up. Cement arm of VR301 as shown in Fig. 7.</li> </ol>		

Adjustment points

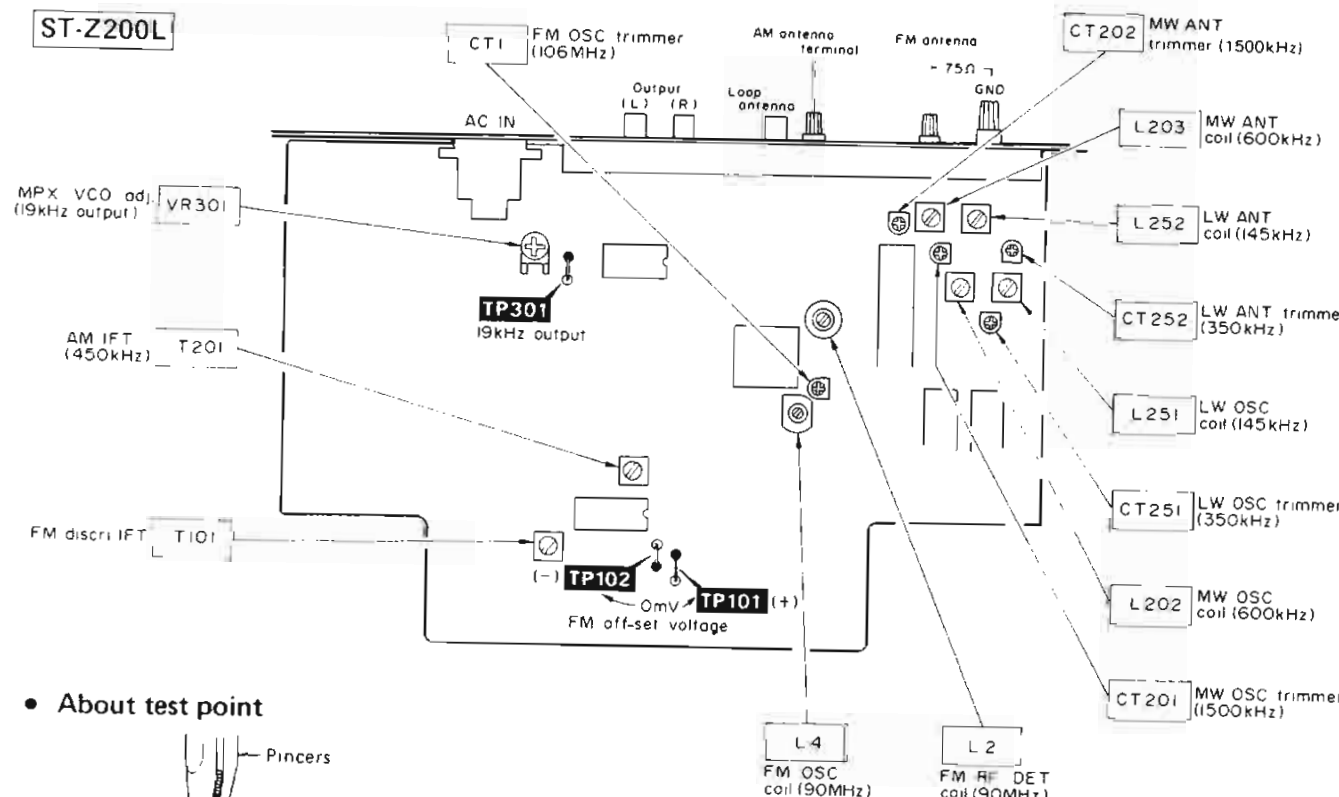
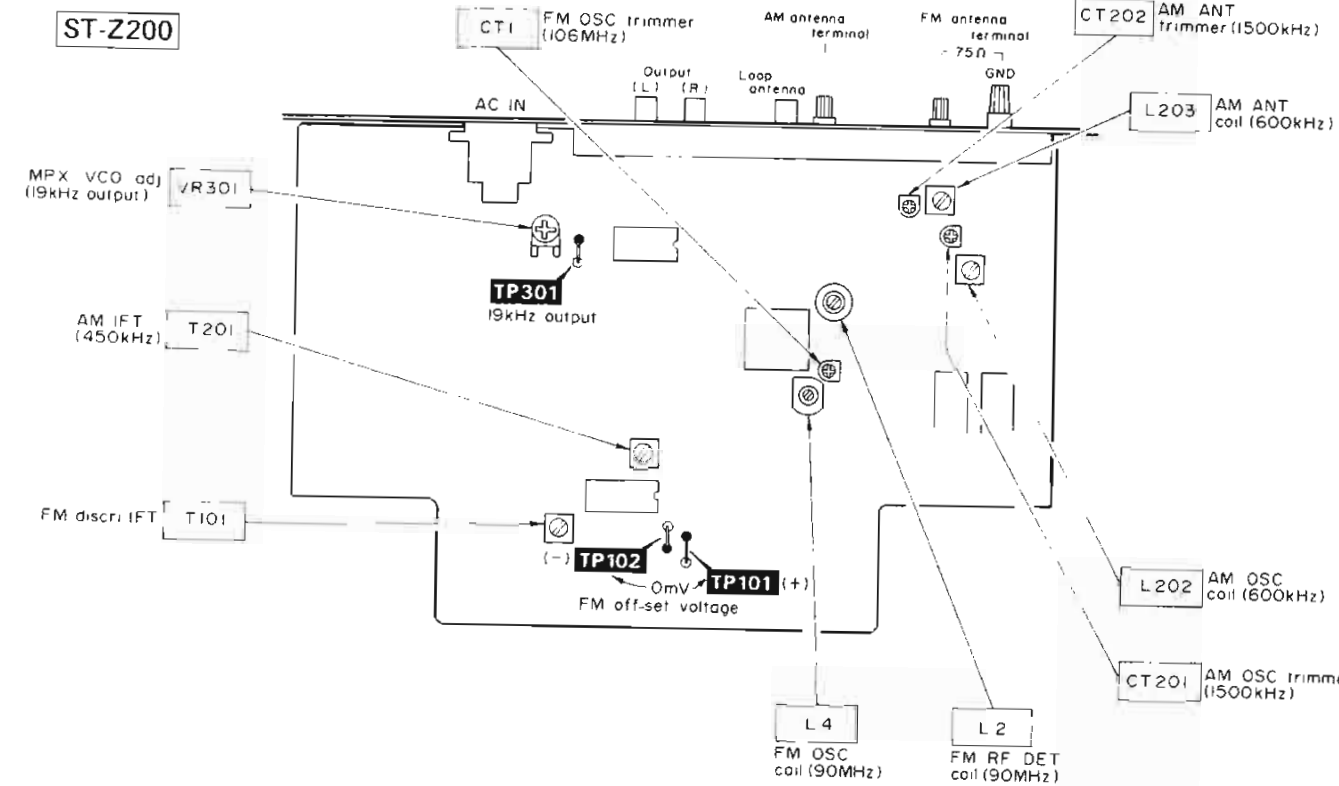

About test point

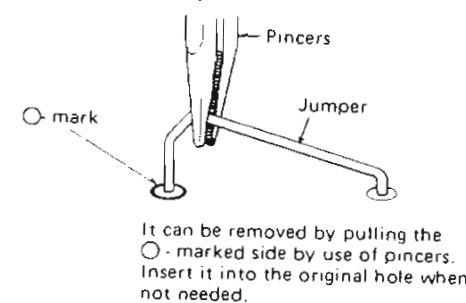

ST-Z200

ST-Z200L

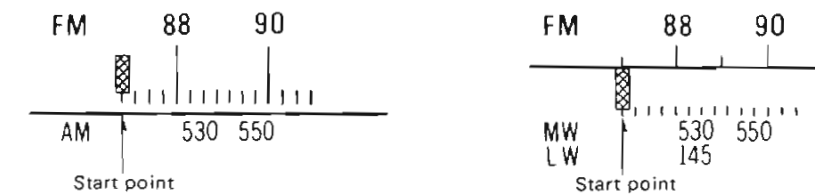

[Fig. 2] Start point

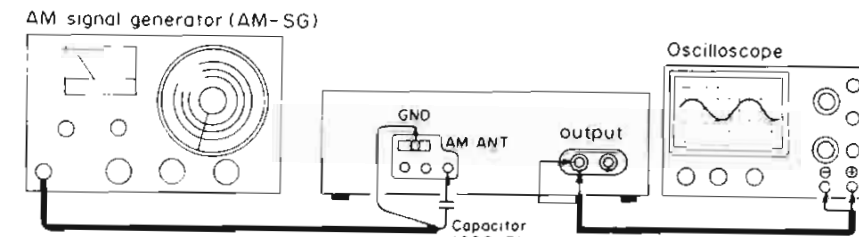

[Fig. 3] AM adjustment

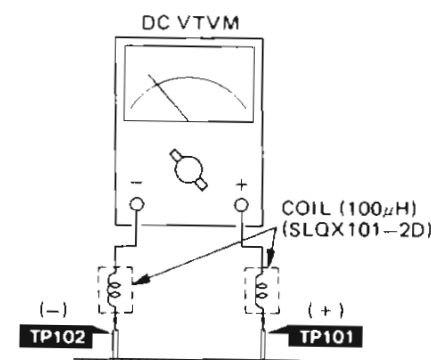

[Fig. 4]

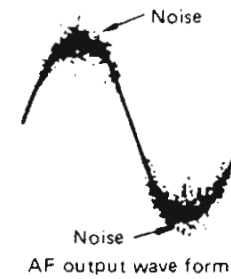

[Fig. 5]

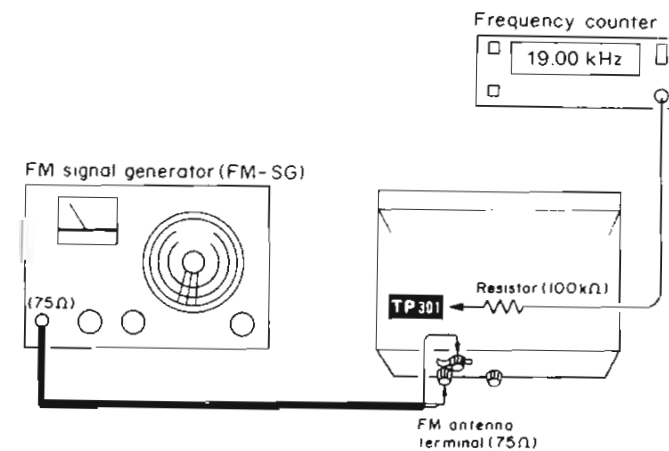

[Fig. 6] FM MPX VCO adjustment

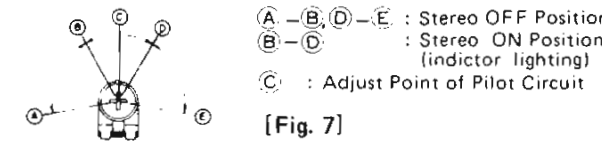

[Fig. 7]

RESISTORS AND CAPACITORS

- Notes:
- Part numbers are indicated on most mechanical parts. Please use this part number for parts orders.
  - Important safety notice: Components identified by  $\Delta$  mark have special characteristics important for safety. When replacing any of these components use only manufacturer's specified parts.
  - The 'S' mark is service standard parts and may differ from production parts.
  - The unit of resistance is OHM ( $\Omega$ ). K = 1000 $\Omega$ , M = 1000K $\Omega$ .
  - The unit of capacitance is MICROFARAD ( $\mu$ F). P = 10<sup>-6</sup>  $\mu$ F.
  - Bracketed indications in Ref. No. columns specify the area. Parts without these indications can be used for all areas.

Numbering System of Resistor

Example	25	F	J	101
Type	Wattage	Shape	Tolerance	Value
ERD	Carbon	25	1/4W	J
ERG	Metal Oxide	1	1W	J

Numbering System of Capacitor

Example	1H	102	Z	F
Type	Voltage	Value	Tolerance	Peculiarity
ECEA	50	M	R47	R
Type	Voltage	Peculiarity use	Value	Special use

\* ECB type capacitor

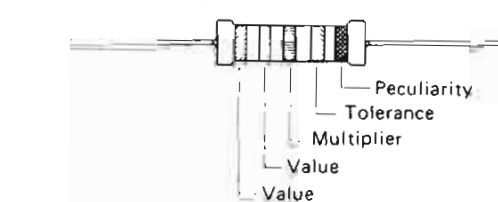

Capacitor Type	Voltage		Tolerance
	ECEA Type	Other	
ECEA Electrolytic	1A 10V	1H .50V DC	C . . . 0.25pF
ECCD Ceramic	1C 16V		J . . . 5%
ECKD Ceramic	1E 25V		K . . . 10%
ECOM Polyester	1V 35V		N . . . 30%
ECOP Polypropylene	1H 50V		Z . . . 80% . . . 20%
ECBT Axial Leaded Type Ceramic	50 50V	25 25V	

ST-Z200

ST-Z200L

Ref. No.	Part No.	Value	Ref. No.	Part No.	Value	Ref. No.	Part No.	Value	Ref. No.	Part No.	Value
RESISTORS			CAPACITORS			RESISTORS			CAPACITORS		
R1	ERD25FJ102	1K	C1	ECCD1H220KC	22P	R1	ERD25FJ102	1K	C1 [EK]	ECCD1H180KC	18P
R2	ERD25FJ220	22	C2	ECCD1H180KC	18P	R2	ERD25FJ220	22	C1 [other]	ECCD1H220KC	22P
R3	ERD25FJ221	220	C3	ECCD1H220KC	22P	R3	ERD25FJ221	220	C2	ECCD1H180KC	18P
R4	ERD25J474	470K	C4	ECBT1H102ZX	0.001	R4	ERD25J474	470K	C3	ECCD1H220KC	22P
R5	ERD25FJ471	470	C5	ECBT1C103ZY	0.01	R5	ERD25FJ471	470	C4	ECBT1H102ZX	0.001
R6	ERD25J393	39K	C6	ECCD1H030CC	3P	R6	ERD25J393	39K	C5	ECBT1C103ZY	0.01
R7	ERD25FJ822	8.2K	C7	ECCD1H070CC	7P	R7	ERD25FJ822	8.2K	C6 [EK]	ECCD1H010CC	1P
R8	ERD25FJ122	1.2K	C8	ECCD1H181K	180P	R8	ERD25FJ122	1.2K	C6 [other]	ECCD1H030CC	3P
R9	ERD25FJ682	6.8K	C9	ECCD1H390KC	39P	R9	ERD25FJ682	6.8K	C7	ECCD1H070CC	7P
R10	ERD25J104	100K	C10	ECCD1H150KC	15P	R10	ERD25J104	100K	C8	ECCD1H181K	180P
R101	ERD25FJ272	2.7K	C11	ECBT1H102ZX	0.001	R101 [EK]	ERD25FJ471	470	C9	ECCD1H390KC	39P
R102	ERD25FJ681	680	C13	ECCD1H080CC	8P	R101 [other]	ERD25FJ272	2.7K	C10	ECCD1H150KC	15P
R103	ERD25J824	820K	C14	ECBT1C103ZY	0.01	R102	ERD25FJ272	2.7K	C11	ECBT1H102ZX	0.001
R104	ERD25J274	270K	C15	ECBT1C223NY	0.022	R102	ERD25FJ681	680	C13 [EK]	ECCD1H050CC	5P
R105, 106	ERD25FJ471	470	C21 [EX, EH]	ECCD1H103ZF	0.01	R103	ERD25J824	820K	C13 [other]	ECCD1H080CC	8P
R107	ERD25FJ152	1.5K	C101	ECBT1C103ZY	0.01	R104	ERD25J274	270K	C14	ECBT1C103ZY	0.01
R108	ERD25FJ103	10K	C102	ECCD1H103ZF	0.01	R105, 106	ERD25FJ471	470	C15	ECBT1C223NY	0.022
R110	ERD25J684	680K	C103, 104	ECCD1H223ZF	0.022	R107	ERD25F1152	1.5K	C20	ECCD1H030CC	3P
R201	ERD25FJ122	1.2K	C106	ECEA1H010	1	R108	ERD25F1103	10.3K	C21 Except [EK]	ECCD1H103ZF	0.01
R202	ERD25FJ681	680	C107	ECBT1C223NY	0.022	R110	ERD25J684	680K	C101 [EK]	ECBT1C103ZY	0.01
R203	ERD25FJ100	10	C108	ECEA1CU100	10	R110 [EK] only	ERD25J683	68K	C102	ECCD1H103ZF	0.01
R204	ERD25FJ220	22	C110	ECCD1H101K	100P	R201	ERD25FJ122	1.2K	C103, 104	ECCD1H223ZF	0.022
R301	ERD25FJ103	10K	C111	ECCD1H473ZF	0.047	R202	ERD25FJ681	680	C106	ECEA1H010	1
R302	ERD25J104	100K	C113	ECEA1EU4R7	4.7	R205	ERD25J473	47K	C107	ECBT1C223NY	0.022
R303, 304	ERD25J223	22K	C114	ECBT1C103ZY	0.01	R251	ERD25FJ102	1K	C108	ECEA1CU100	10
R305	ERD25J334	330K	C204	ECCD1H223ZF	0.022	R252	ERD25FJ103	10K	C110	ECCD1H101K	100P
R306	ERD25J153	15K	C205	ECEA1AU101	100	R301	ERD25FJ103	10K	C111	ECCD1H473ZF	0.047
R308	ERD25FJ103	10K	C206	ECEA1EU4R7	4.7	R302	ERD25J104	100K	C113	ECEA1EU4R7	4.7
R309	ERD25FJ821	820	C207	ECCD1H330K	33P	R303, 304	ERD25J223	22K	C114	ECBT1C103ZY	0.01
R310, 311	ERD25FJ222	22K	C301	ECEA1EU4R7	4.7	R305	ERD25J334	330K	C202	ECCD1H120KC	12P
R312, 313	ERD25J333	33K	C302	ECEA1CU101	100	R306	ERD25J153	15K	C203	ECOP1351JZ	360P
R314	ERD25J473	47K	C303	ECCD1H473ZF	0.047	R308	ERD25FJ103	10K	C204	ECCD1H223ZF	0.022
R315	ERD25J330	33K	C304	ECCD1471JZ	47P	R309	ERD25J821	820	C205	ECEA1AU101	100
R404	ERD25FJ102	1K	C305, 306	ECEA1HUR47	0.47	R310, 311	ERD25FJ222	22K	C206	ECEA1EU4R7	4.7
R501	ERD25FJ182	1.8K	C307, 308	ECOM1H223JZ	0.022	R312, 313	ERD25J333	33K	C207	ECCD1H270K	27P
R503	ERD25FJ472	4.7K	C309, 310	ECEA1HUR47	0.47	R314	ERD25J473	47K	C251	ECCD1H070K	7P
R504	ERD25FJ392	3.9K	C501	ECEA0JU470	47	R315	ERD25J330	33K	C252	ECCD1H680CC	68P
R505	ERD25FJ103	10K	C503	ECEA1CU100	10	R404	ERD25FJ102	1K	C253	ECOP181JZ	180P
R506	ERD25J333	33K	C504	ECBT1C103ZY	0.01	R501	ERD25FJ182	1.8K	C301	ECEA1EU4R7	4.7
R507, 508	ERD25J563	56K	C701, 702	ECEA1CU221	220	R503	ERD25FJ472	4.7K	C302	ECEA1CU101	100
R509	ERD25FJ122	1.2K	C703	ECCD1H103ZF	0.01	R504	ERD25FJ392	3.9K	C303	ECCD1H473ZF	0.047
R510	ERD25FJ822	8.2K	C704	ECEA1VU221	220	R505	ERD25FJ103	10K	C304	ECOP1471JZ	470P
R511	ERD25FJ471	470	C705	ECEA1CU221	220	R506	ERD25J333	33K	C305, 306	ECEA1HUR47	0.47
R701	ERG1ANJ470	47	C707	ECCD1H103ZF	0.01	R507, 508	ERD25J563	56K	C307, 308	ECOM1H223JZ	0.022
R702	ERD25FJ122	1.2K				R509	ERD25FJ122	1.2K	C309, 310	ECEA1HUR47	0.47
R703	ERD25FJ561	560				R510	ERD25FJ822	8.2K	C501	ECEA0JU470	47
						R511	ERD25FJ471	470	C504	ECBT1C103ZY	0.01
						R701	ERG1ANJ470	47	C701, 702	ECEA1CU221	220
						R702	ERD25FJ122	1.2K	C703	ECCD1H103ZF	0.01
						R703	ERD25FJ561	560	C704	ECCD1H103ZF	0.01
									C705	ECEA1CU221	220
									C707	ECCD1H103ZF	0.01
									C708	ECCD1H103ZF	0.01



CIRCUIT BOARDS AND WIRING CONNECTION DIAGRAM

ST-Z200

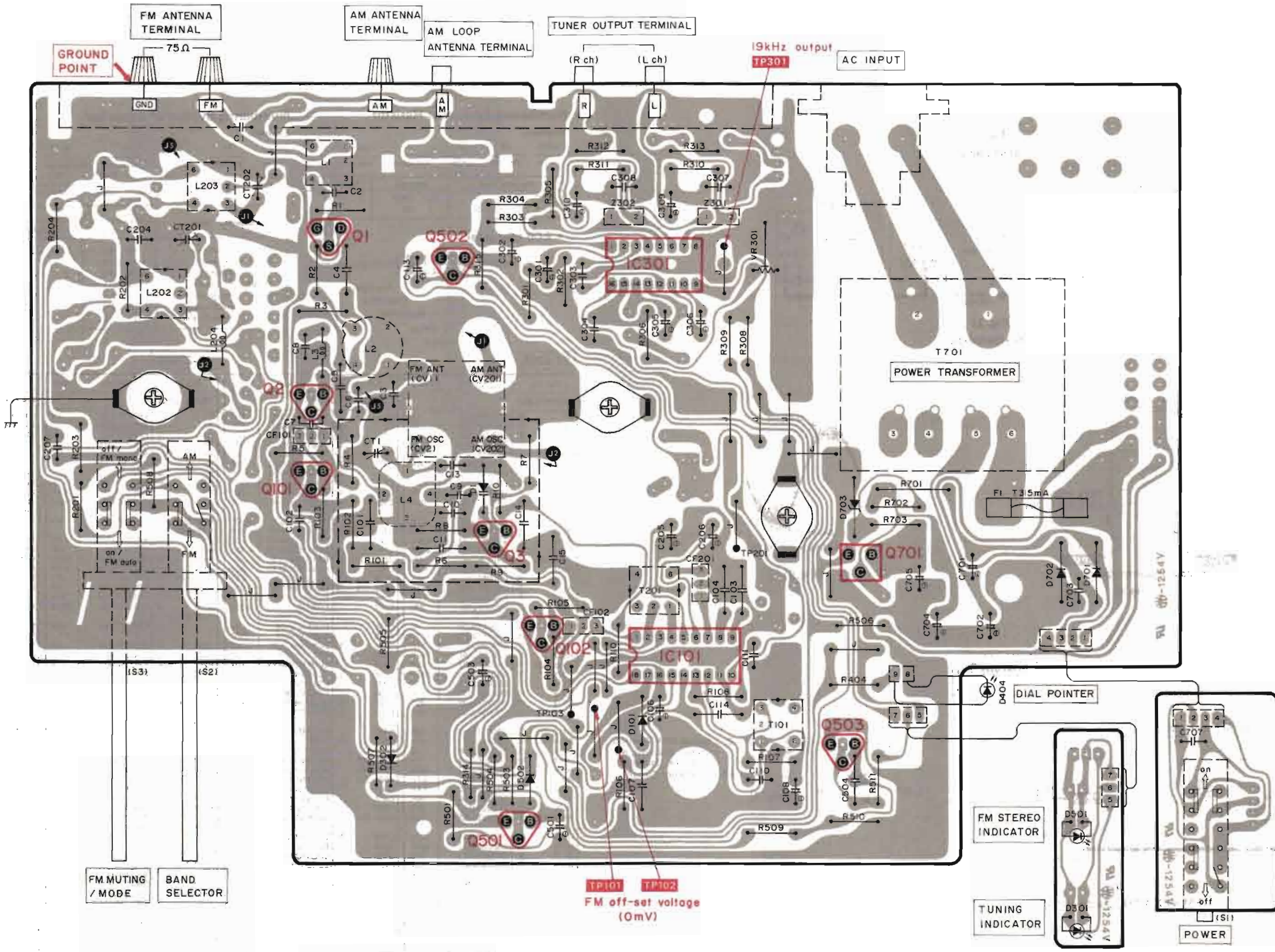



ST-Z200L

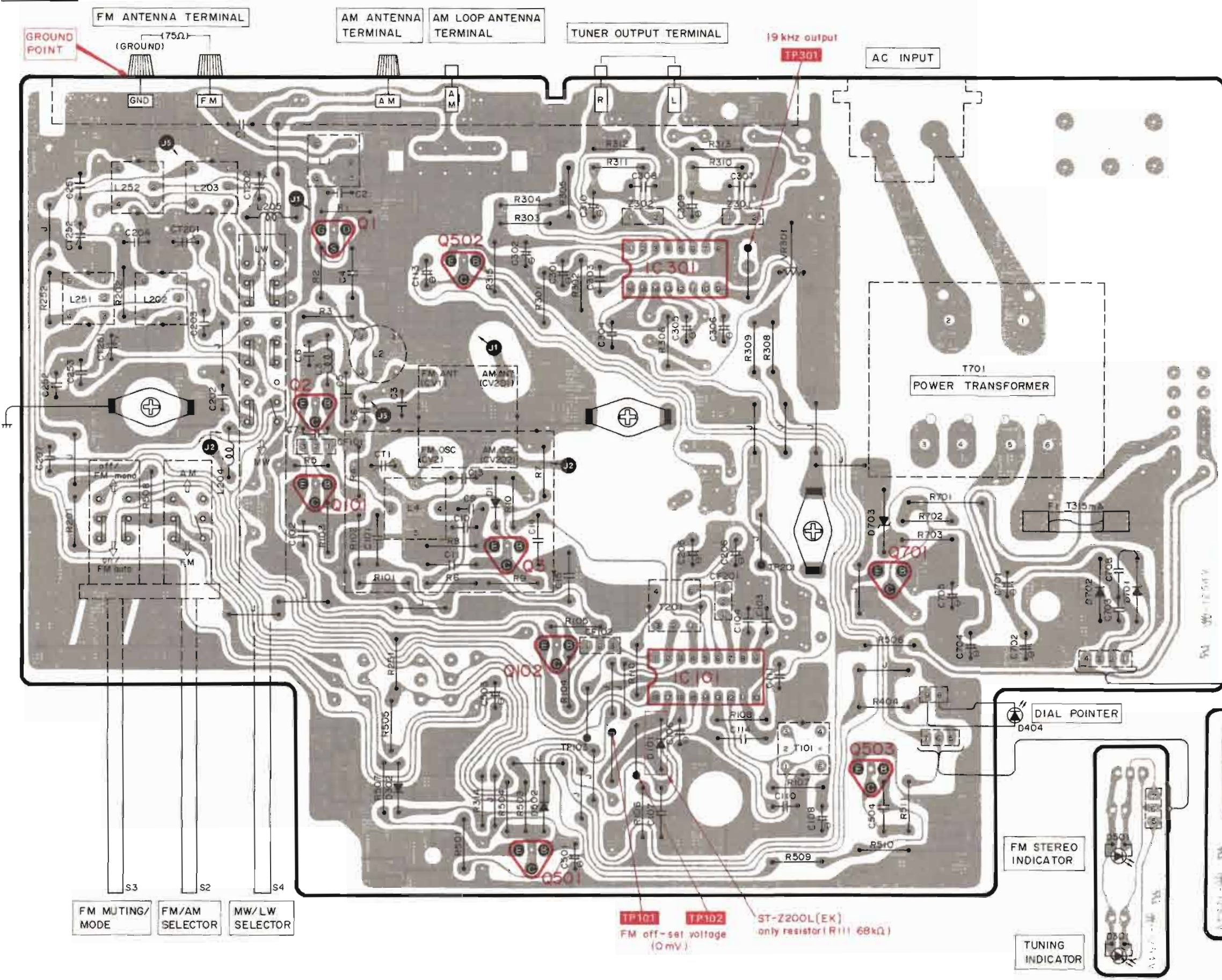

• Terminal guide of transistors, IC's and diodes (ST-Z200/ST-200L)

	AN7273B 18 pin
	SVIμPC1161C3 16 pin
	2SC1674, 2SC1675, 2SC945
	2SD882
	LN446YP, LN846RP
	MA150
	SVDMZ312C
	2SK193
	SVD1S2687AA7
	SVDSR1K2

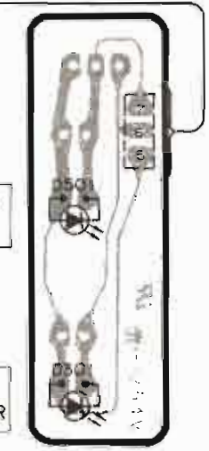
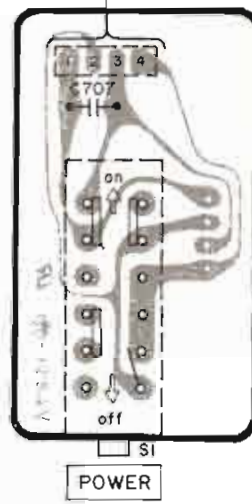

TP101 TP102 ST-Z200L(EK) only resistor (R111 68kΩ)  
FM off-set voltage (0mV)

S3 FM MUTING/MODE  
S2 FM/AM SELECTOR  
S4 MW/LW SELECTOR

DIAL POINTER D404

FM STEREO INDICATOR

TUNING INDICATOR

POWER



# ST-Z200/Z200L ST-Z200/Z200L

## ■ BLOCK DIAGRAM

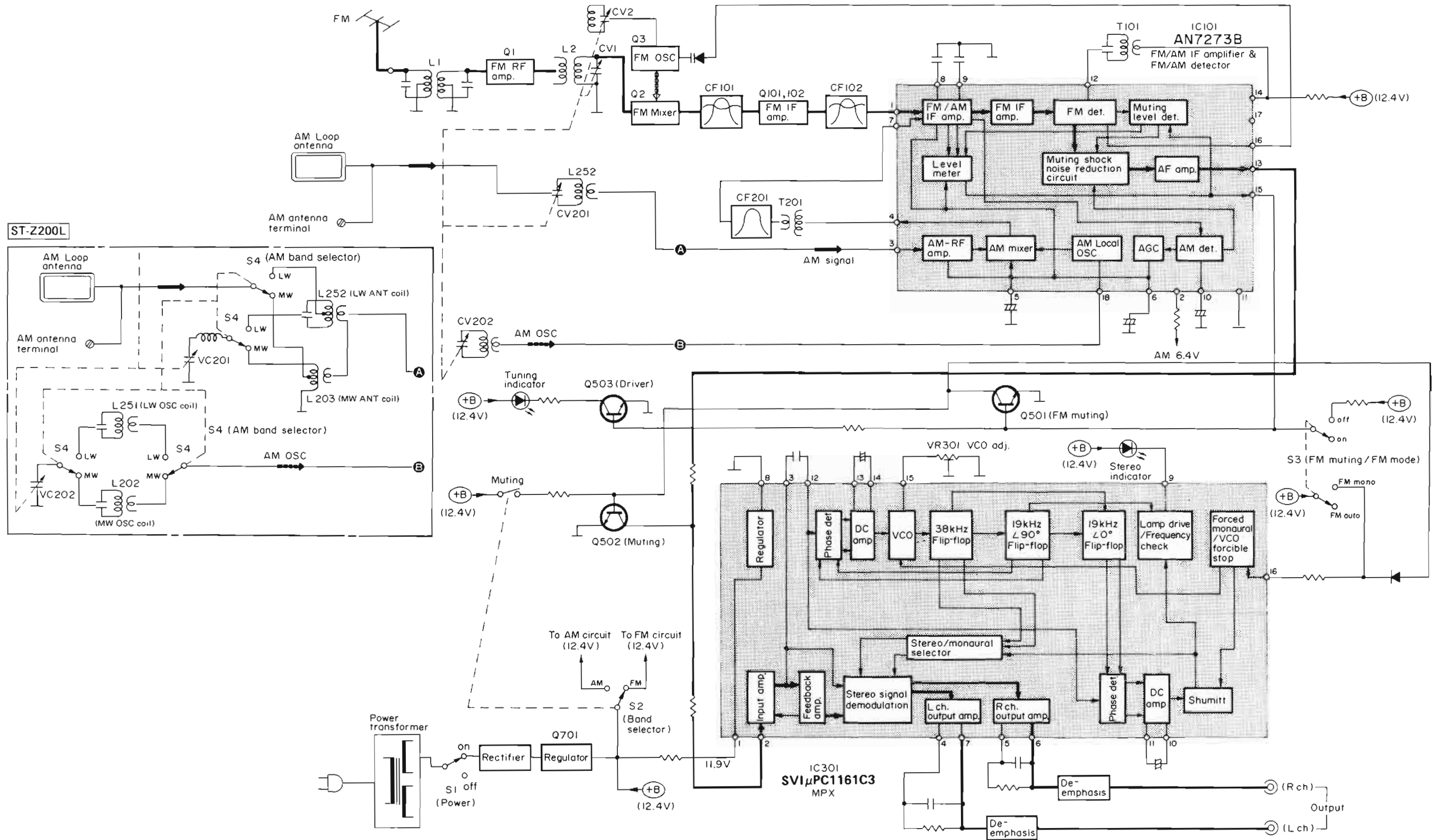



SCHEMATIC DIAGRAM

(This schematic diagram may be modified at any time with the development of new technology.)

**Note 1:** The part No. of transistors, IC and diodes mentioned in the schematic diagram stand for production part No. Regarding the part No. with ⊕ mark, the production part No. are different from the replacement part No. Therefore, when placing an order for replacement part, please use the part No. in the replacement part list.

- Note:**
- S1 : Power source switch in "on" position.
  - S2 : Band selector switch in "FM" position.  
FM ← AM
  - S3 : FM muting/FM mode selector switch in "on/FM auto" position.  
on/FM auto ← off/FM mono
  - S4 (ST-Z200L only) : AM band selector switch in "MW" position.  
MW ← LW
  - S5 [XA] only : Voltage selector switch in "220V" position  
110V ← 120V ← 220V ← 240V
6. Indicated voltage values are the standard values for the unit measured by the DC electronic circuit tester (high-impedance) with the chassis taken as standard. Therefore, may exist some errors in the voltage values, depending on the internal impedance of the DC circuit tester.
- \* Figures in ◁ stand for DC voltage in FM signal (no signal) mode.
  - \* Figures in ▷ stand for DC voltage in FM stereo signal reception mode.
  - \* Figures in ▭ stand for DC voltage in AM signal reception mode.
7. Positive voltage lines  
FM signal lines  
AM signal lines  
FM OSC  
AM (MW, LW) OSC
8. Important safety notice.  
Components identified by ⊕ mark have special characteristics important for safety. When replacing any of these components, use only manufacturer's specified parts.

**Note 2:** Muting switch part. When switch is turned on it is positioned as shown only for a moment. Usually, it is not connected to the circuit.

Power source circuit

• Product for Australia [XL] only

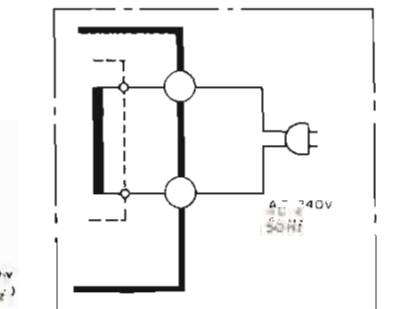

• Product for [XA] only

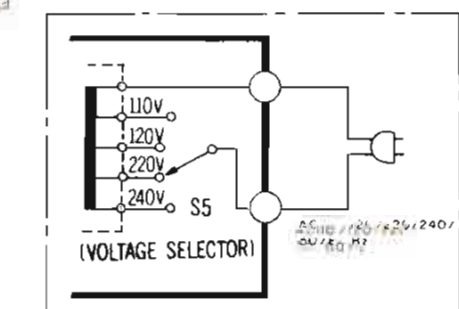

[XA] is available in Southeast Asia, Oceania, Africa, Middle Near East and Central South America.

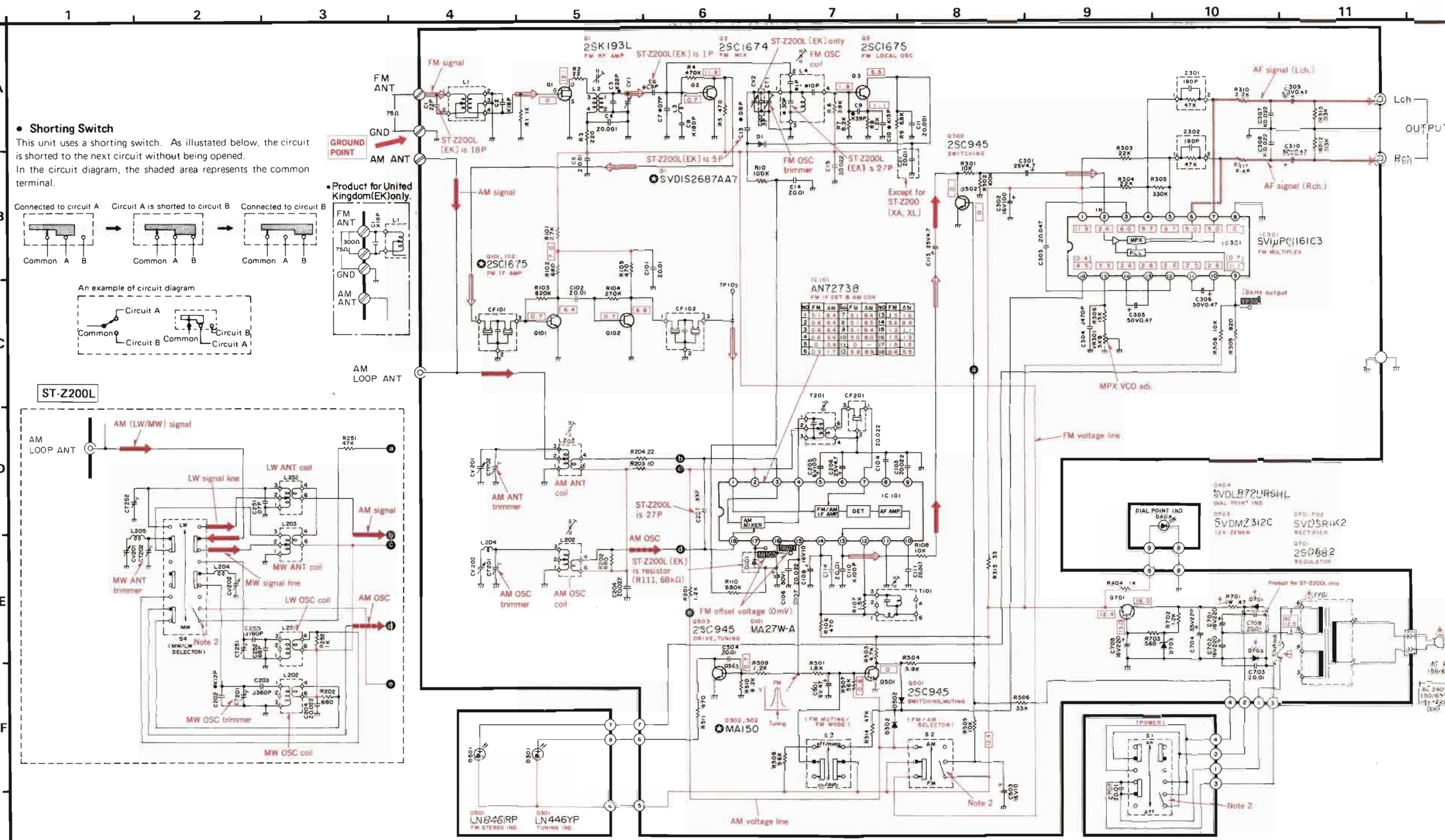

**Shorting Switch**  
This unit uses a shorting switch. As illustrated below, the circuit is shorted to the next circuit without being opened. In the circuit diagram, the shaded area represents the common terminal.

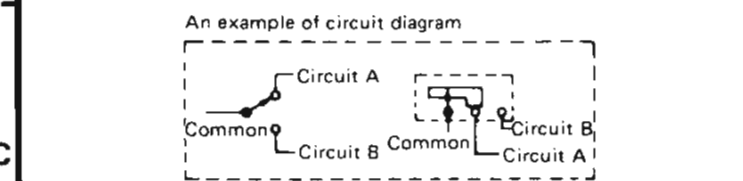
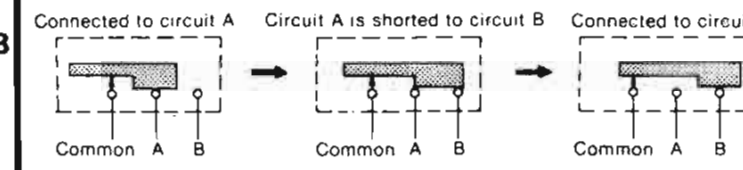

ST-Z200L

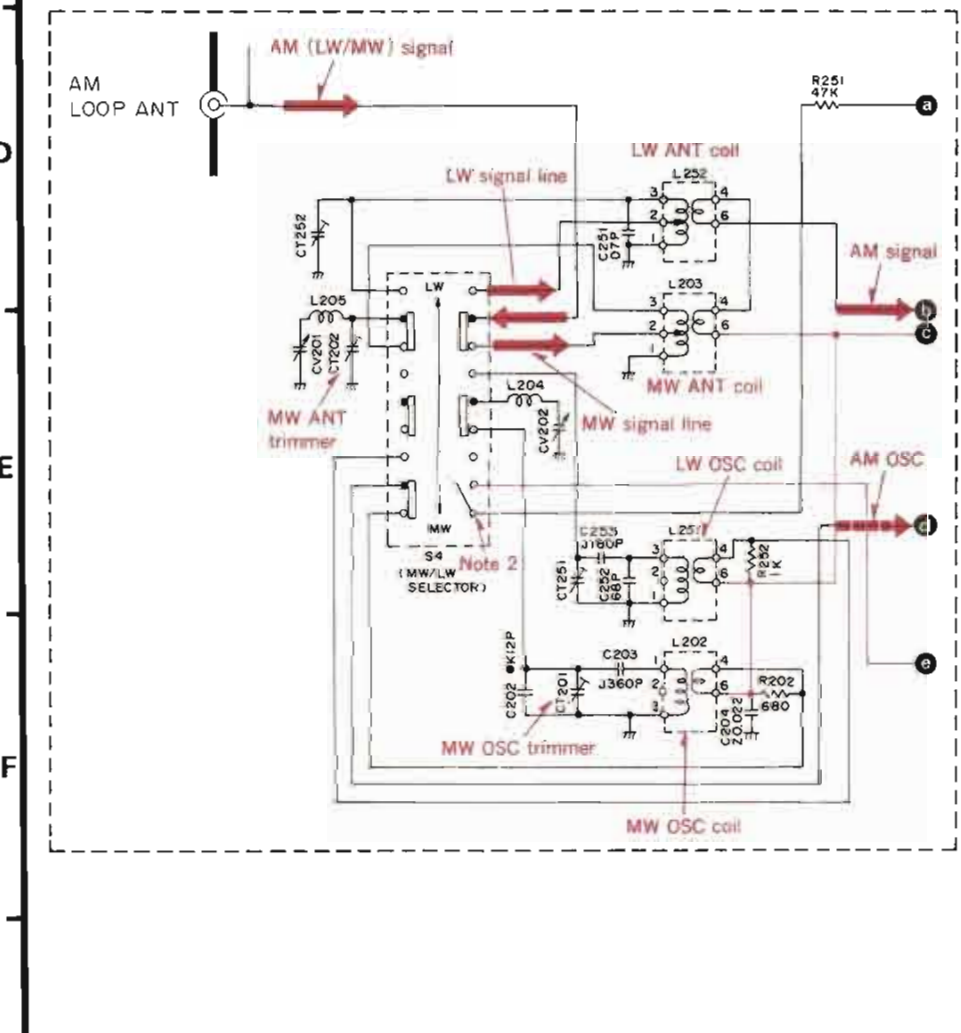



REPLACEMENT PARTS LIST

- Notes: 1. Part numbers are indicated on most mechanical parts. Please use this part number for parts order.  
 2. Important safety notice: Components identified by  $\Delta$  mark have special characteristics important for safety. When replacing any of these components, use only manufacturer's specified parts.  
 3.  $\otimes$  - marked parts are used for black only, while  $\circ$  - marked parts are for silver type only.  
 4. Part other than  $\otimes$  - and  $\circ$  - marked are use for both black and silver type.

5. Bracketed indications in Ref. No. columns specify the area. Parts without these indications can be used for all areas.  
 6. The "S" mark is service standard parts and may differ from production parts.  
 7. The parenthesized numbers in the column of description stand for the quantity per set.

ST-Z200			MELUK = Made in United Kingdom.		
Ref. No.	Part No.	Description	Ref. No.	Part No.	Description
<b>INTEGRATED CIRCUITS</b>					
IC101	AN7273B	FM/AM Detector			
IC301	SVIUCP1161C3	FM MPX			
<b>TRANSISTORS</b>					
Q1	2SK193-LF	FM RF AMP			
Q2	2SC1674-M	FM Mixer			
Q3,101,102	2SC1675-L	FM OSC			
Q501,502,503	2SC945-O	Switching Driver			
Q701	2SD793-P	Mixer, OSC Buffer			
<b>DIODES</b>					
D1	SVD1S2687AA7	FM AFC			
D301	MA27W-A	Switching L.E.D			
D302,502	LN446YP	Switching L.E.D			
D501	LN846RP	Switching L.E.D			
D701,702	SVDSRIK2	Rectifier			
D703	SVDMZ312C	12V. Zener			
D404	SVDLB72UR5HL	L.E.D			
<b>COILS</b>					
L1	SLA4N39	FM Antenna			
L2	SLO4P71-P	FM Detector			
L3,204	SLOZ12G1-D	Choke			
L4	SLO4P121-P	FM OSC			
L202	SLOZ12G1-D	AM OSC			
L203	SLA2C9-P	AM Antenna			
<b>TRANSFORMERS</b>					
T101	SLI4C539-P	FM IFT			
T201	SLI2C139-M	AM IFT			
T701 (XL)	SLT5J189	Power Source			
T701 (EK,EH)	SLT5K123	Power Source			
T701 (other)	SLT5K127	Power Source			
<b>CERAMIC FILTERS</b>					
CF101,102	SVFE107MS2-A	10.700MHz (Red)			
	SVFE107MS2-B	10.675MHz (Blue)			
	SVFE107MS2-C	10.725MHz (Orange)			
	SVFE107MS2-D	10.650MHz (Black)			
	SVFE107MS2-E	10.750MHz (White)			
<b>ACCESSORIES</b>					
A1 (XL)	SJA163	Cord. Power Source			
A1 (PA,PE)	SJA168	Cord. Power Source			
A1 (other)	SFDAC05E02	Cord. Power Source			
A2	SJP2129-5	Cord. Pin			
A3	SSA269	Antenna, FM			
A4	SSA611-1	Antenna, AM			
A5	SMA231	Holder, AM Antenna			
A6	SMA233-1	Holder, AM Antenna			
A7	XTN3+10AFZ	Tapping, $\phi 3 \times 10$			
A8 (PA,PE) only	SJP9215	Plug, Adaptor			
A9 (XA) only	SJP5213-1	Plug, Adaptor			
A10 (EX, EB)	SQF12077	Instruction Book			
A10 (XA)	SQF12078	Instruction Book			
A10 (XL)	SQF12079	Instruction Book			
A10 (PA,PE)	SQF12080	Instruction Book			
<b>PACKING PARTS</b>					
P1	SPG4902	Carton Box			
P1	SPG4900	Carton Box			
P1 (XL) only	SPG4901	Carton Box			
P2 (XL)	SPS4456-1	Pad, Left			
P2 (other)	SPS4456	Pad, Left			
P3 (XL)	SPS4457-1	Pad, Right			
P3 (other)	SPS4457	Pad, Right			
P4	SPS4458	Pad			
P5	SPP697	Polyethylene Bag			
P5	SPP734	Polyethylene Bag			

ST-Z200L

Ref. No.	Part No.	Description
<b>INTEGRATED CIRCUITS</b>		
IC101	AN7273B	FM/AM Detector
IC301	SVIUCP1161C3	FM MPX
<b>TRANSISTORS</b>		
Q1	2SK193-LF	FM RF AMP
Q2	2SC1674-M	FM Mixer
Q3,101,102	2SC1675-L	FM OSC
Q501,502,503	2SC945-O	Switching Driver
Q701	2SD793-P	Mixer, OSC Buffer
<b>DIODES</b>		
D1	SVD1S2687AA7	FM AFC
D301	MA27W-A	Switching L.E.D
D302,502	LN446YP	Switching L.E.D
D501	LN846RP	Switching L.E.D
D701,702	SVDSRIK2	Rectifier
D703	SVDMZ312C	12V. Zener
D404	SVDLB72UR5HL	L.E.D
<b>COILS</b>		
L1	SLA4N39	FM Antenna
L2	SLO4P71-P	FM Detector
L3,204	SLOZ12G1-D	Choke
L4	SLO4P121-P	FM OSC
L202	SLOZ12G1-D	AM OSC
L203	SLA2C9-P	AM Antenna
L251	SLO1C13-P	Choke
L252	SLA1C13-P	Antenna
<b>TRANSFORMERS</b>		
T101	SLI4C539-P	FM IFT
T201	SLI2C139-M	AM IFT
T701 (EK)	SLT5K125	Power Source
T701 (other)	SLT5K123	Power Source
<b>CERAMIC FILTERS</b>		
CF101,102	SVFE107MS2-A	10.700MHz (Red)
	SVFE107MS2-B	10.675MHz (Blue)
	SVFE107MS2-C	10.725MHz (Orange)
	SVFE107MS2-D	10.650MHz (Black)
	SVFE107MS2-E	10.750MHz (White)
<b>ACCESSORIES</b>		
A1 (XL)	SJA163	Cord. Power Source
A1 (PA,PE)	SJA168	Cord. Power Source
A1 (other)	SFDAC05E02	Cord. Power Source
A2	SJP2129-5	Cord. Pin
A3	SSA269	Antenna, FM
A4	SSA611-1	Antenna, AM
A5	SMA231	Holder, AM Antenna
A6	SMA233-1	Holder, AM Antenna
A7	XTN3+10AFZ	Tapping, $\phi 3 \times 10$
A8 (PA,PE) only	SJP9215	Plug, Adaptor
A9 (XA) only	SJP5213-1	Plug, Adaptor
A10 (EX, EB)	SQF12077	Instruction Book
A10 (XA)	SQF12078	Instruction Book
A10 (XL)	SQF12079	Instruction Book
A10 (PA,PE)	SQF12080	Instruction Book
<b>PACKING PARTS</b>		
P1	SPG4902	Carton Box
P1	SPG4900	Carton Box
P1 (XL) only	SPG4901	Carton Box
P2 (XL)	SPS4456-1	Pad, Left
P2 (other)	SPS4456	Pad, Left
P3 (XL)	SPS4457-1	Pad, Right
P3 (other)	SPS4457	Pad, Right
P4	SPS4458	Pad
P5	SPP697	Polyethylene Bag
P5	SPP734	Polyethylene Bag

EXPLODED VIEW

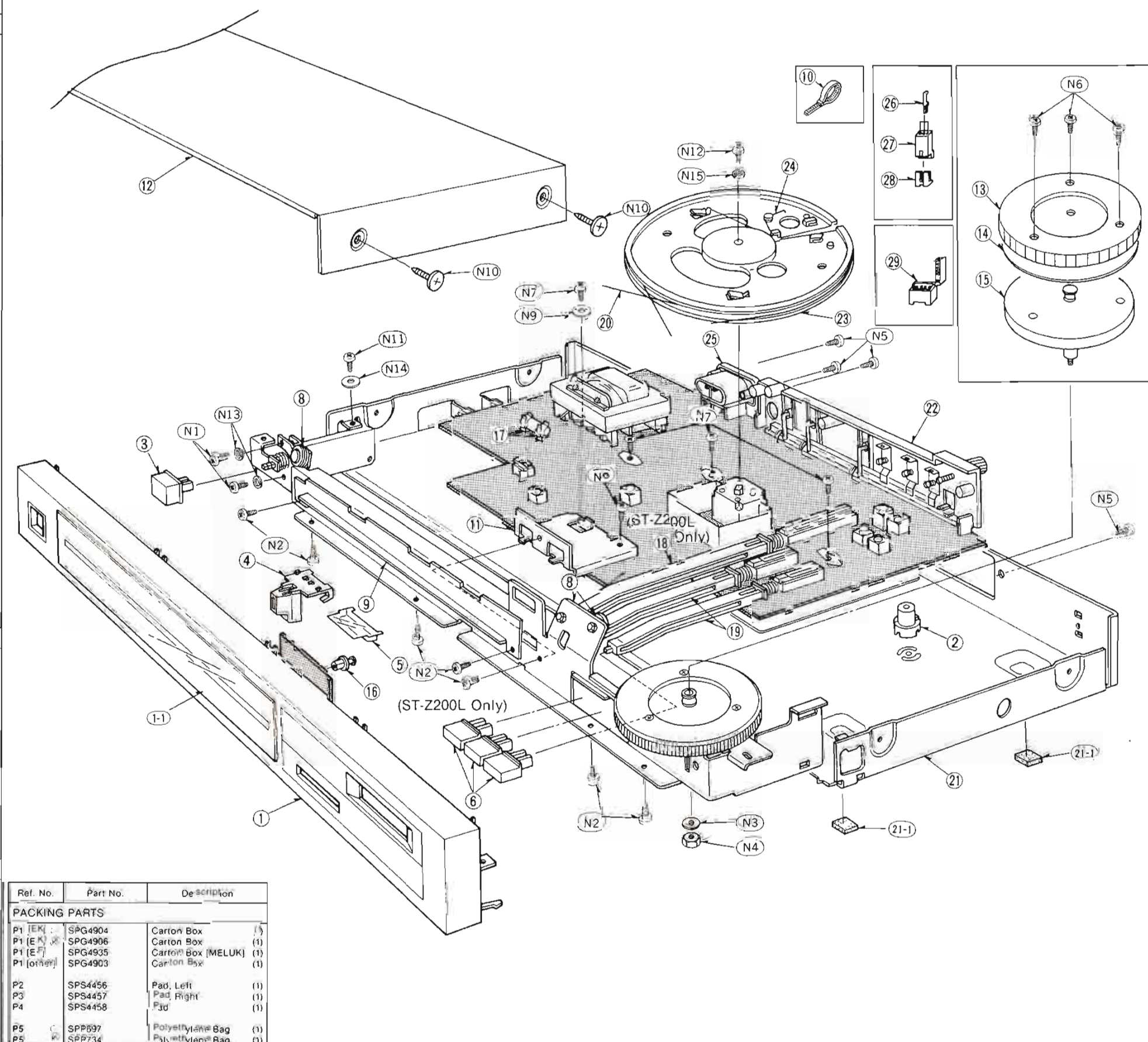

Ref. No.	Part No.	Description
<b>CABINET and CHASSIS PARTS</b>		
1	SGWTZ200L-SE	Front Panel Assy (Silver)
1	SGWTZ200L-KE	Front Panel Assy (Black)
1-1	SKD6025M	Dial Scale (Silver)
1-1	SKD6024M	Dial Scale (Black)
2	SHE170	Holder, P.C.B
3	SBC627	Button, Power
4	SDP5089	Source Pointer, Dial Assy
5	SHR31-2	Spacer, Pointer
6	SBC433-1	Button, Pointer
7	SUS295-1	Spring
8	SDR31	Drum
9	SUW2856	Bracket
10	SHR301	Clamper, Lead Wire
11	SUW2845	Sub. Plate, P.C.B
12	SKC1331S	Cabinet (Silver)
12	SKC1331BB	Cabinet (Black)
13	SBN1147-3	Knob, Tuning
14	SHR5243	Insulation Sheet
15	SD78097-3	Fry Wheel
16	SHR415	Latch, P.C.B
17	SJT347	Terminal, Fuse
18	SUB195	Connection Rod
19	SUB196	Connection Rod
20	SDZ051-2	Card, Dial
21 (EX)	SGPTZ200L-SE	Rear Panel Assy (w/Feet)
21 (EK)	SGPTZ200L-SK	Rear Panel Assy (w/Feet)
21 (EF)	SGPTZ200L-SF	Rear Panel Assy (w/Feet) [MELUK]
21 (EB)	SGPTZ200L-SB	Rear Panel Assy (w/Feet)
21-1	SHS2481	Foot
22 (EK)	SJF8711N	Terminal Board
22 (other)	SJF8607N	Terminal Board
23	SDD105-1	Drum
24	SUS295-1	Spring
25	SJS9230	Socket, AC Inlet
26	SJT783	Terminal
27	SJS5215	Socket (2 pin)
28	SJT3213	Post (2 pin)
29	SJS5327	Post (3 pin)
<b>SCREWS WASHERS and NUTS</b>		
N1	XSN3+6S	$\phi 3 \times 6$
N2	XTB3+8BFZ	Tapping, $\phi 3 \times 8$
N3	XWD11B	Washer with Detent $\phi 11$
N4	XNS11	Nut, $\phi 11$
N5	XTB3+8BFZ	Tapping, $\phi 3 \times 8$
N6	XSS3+6S	$\phi 3 \times 6$ , Flywheel
N7	XTB3+12BFN	Tapping, $\phi 3 \times 12$
N8	XTB3+6B	Tapping, $\phi 3 \times 6$
N9	XWG3	Thin, $\phi 3$
N10	SNE2095-4	Cabinet (Silver)
N10	SNE2095-5	Cabinet (Black)
N11	XTV3+10BFN	Tapping, $\phi 3 \times 10$
N12	XSN26+5BN	$\phi 2.6 \times 5$
N13	XWA3B	Spring, $\phi 3$
N14	XWG3	Thin, $\phi 3$
N15	XWA26	Spring, $\phi 2.6$
<b>ACCESSORIES</b>		
A1 (EK)	SFDAC05G02	Cord. Power Source
A1 (other)	SFDAC05E02	Cord. Power Source
A2	SJP2129-5	Cord. Pin
A3	SSA269	Antenna, FM
A4	SSA611-1	Antenna, AM
A5	SMA231	Holder, AM Antenna
A6	SMA233-1	Holder, AM Antenna
A7	XTN3+10AFZ	Tapping, $\phi 3 \times 10$
A8 (EK)	SQF12079	Instruction Book
A8 (EF)	SQF12078	Instruction Book [MELUK]
A8 (other)	SQF12077	Instruction Book

Ref. No.	Part No.	Description
<b>PACKING PARTS</b>		
P1 (EK)	SPG4904	Carton Box
P1 (EK)	SPG4906	Carton Box
P1 (EF)	SPG4935	Carton Box [MELUK]
P1 (other)	SPG4903	Carton Box
P2	SPS4456	Pad, Left
P3	SPS4457	Pad, Right
P4	SPS4458	Pad
P5	SPP697	Polyethylene Bag
P5	SPP734	Polyethylene Bag