

SERVICE MANUAL

**MODEL 1466 & 1476
10 MHz, TRIGGERED SWEEP
Oscilloscope**

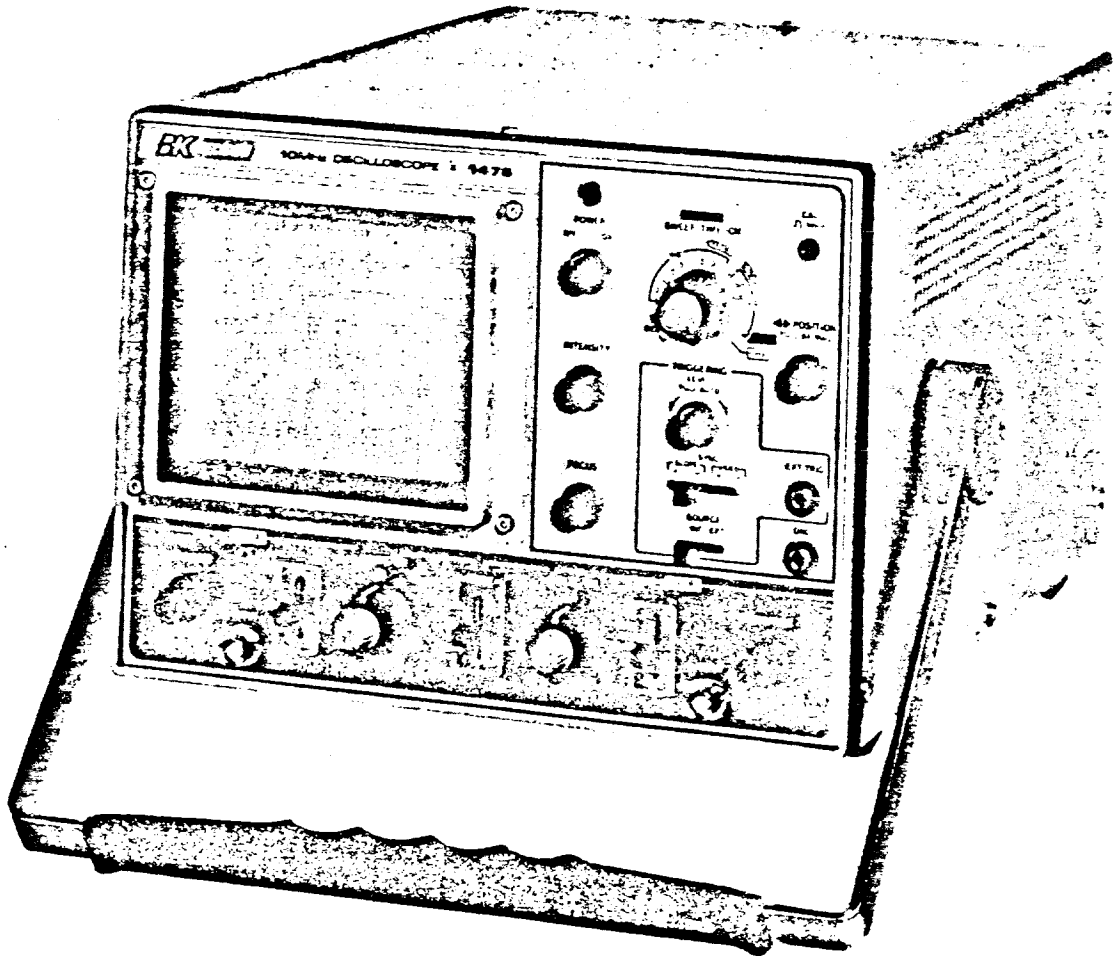

SERVICE MANUAL

FOR

B & K-PRECISION

MODEL 1466 & 1476

10 MHz

TRIGGERED SWEEP

OSCILLOSCOPE

WARNING

This service manual is intended for use by qualified electronics technicians only. To avoid electric shock, do not perform servicing unless you are qualified to do so.

High voltages up to 2000 V are present when this instrument is operating. Line voltage (120 or 240 VAC) is present on the power input receptacle, line voltage selector, fuse and power transformer whenever the AC power cord is connected to a live outlet, even if the scope is turned off. Remember, the battery charger circuit continues to operate when the POWER switch is off. Observe all high voltage safety precautions when the housing is removed from the oscilloscope. Contacting exposed high voltage could result in fatal electric shock.

HIGH VOLTAGE PRECAUTIONS

WARNING

Normal use of test equipment exposes you to a certain amount of danger from electrical shock because testing must often be performed where exposed voltage is present. An electrical shock causing 10 milliamps of current to pass through the heart will stop most human heartbeats. Higher voltages pose an even greater threat because such voltage can more easily produce a lethal current. However, voltage as low as 35 volts dc or ac rms should be considered dangerous and hazardous since it can produce a lethal current under certain conditions. Your normal work habits should include all accepted practices that will prevent contact with exposed high voltage, and that will steer current away from your heart in case of accidental contact with a high voltage. You will significantly reduce the risk factor if you know and observe the following safety precautions:

1. Don't expose high voltage needlessly. Remove housings and covers only when necessary. Turn off equipment while making test connections in high-voltage circuits. Discharge high-voltage capacitors after removing power.
2. Use an insulated floor material or a large, insulated floor mat to stand on, and an insulated work surface on which to place equipment; and make certain such surfaces are not damp or wet. Where insulated floor surface is not available, wear heavy gloves.
3. Use the time-proven "one hand in the pocket" technique while handling an instrument probe. Be particularly careful to avoid contacting a nearby metal object that could provide a good ground return path.
4. Always use an isolation transformer to power transformerless "hot chassis" equipment, where one side of the ac power line is connected directly to the chassis. This includes most recent television sets and audio equipment. Without an isolation transformer, the chassis of such equipment may be floating at line voltage (120 VAC, 60 Hz in USA), depending upon which way the 2-wire ac power plug is inserted. Not only does this present a dangerous shock hazard if the chassis is touched, but damage to test instruments or the equipment under test may result from connecting the ground lead of some test instruments to a "hot" chassis. The ground lead of most oscilloscopes and most other test instruments with 3-wire power plugs is at earth ground. The B & K-PRECISION Model TR-110 Isolation Transformer is suitable for most applications.
5. On test instruments or any equipment with a 3-wire ac power plug, use only a 3-wire outlet. This is a safety feature to keep the housing or other exposed elements at earth ground.
6. If possible, familiarize yourself with the equipment being tested and the location of its high voltage points. However, remember that high voltage may appear at unexpected points in defective equipment.
7. Also remember that ac line voltage is present on some power input current points such as on-off switches, fuses, power transformers, etc., even when the equipment is turned off.
8. Never work alone. Someone should be nearby to render aid if necessary. Training on CPR (cardo-pulmonary resuscitation) first aid is highly recommended.

SPECIFICATIONS Model 1466

Fully regulated internal supplies; calibration accuracy applies over specified input voltage range.

VERTICAL AMPLIFIER

Deflection Factor	0.01 V/cm to 20 V/cm in 11 calibrated ranges in 1-2-5 sequence. Vernier provided for fine adjustment.
Calibration Accuracy	±5% on all ranges.
Frequency Response	DC: DC to 10 MHz (-3 dB). AC: 2 Hz to 10 MHz (-3 dB).
Risetime	35 nanoseconds.
Overshoot	3% or less at 100 kHz square wave display.
Ringing	3% or less at 100 kHz square wave display.
Input Resistance	1 megohm, ±5%.
Input Capacity	22 pF (±3 pF).
Max. Input Voltage	300 V (DC + AC peak) or 600 V p-p.

SWEEP CIRCUITS

Sweep System	Triggered and automatic. In automatic mode, sweep is obtained without input signal.
Sweep Time	1 μSEC/cm to 0.5 SEC/cm in 18 calibrated ranges, in 1-2-5 sequence. Vernier provided for fine adjustment.
Sweep Time Accuracy	±5%.
Sweep Magnification	Obtained by enlarging the above sweep 5 times from center. Maximum sweep speed becomes 0.2 μSEC/cm.
Horizontal Linearity	3% or less distortion. (5 μSEC/cm ~ 0.5 SEC/cm) 5% or less distortion (1 μSEC/cm ~ 2 μSEC/cm)

TRIGGERING

Source	INT and EXT (1 V p-p sensitivity).
Slope	Positive and negative, continuously variable level control; pull for AUTO.
Triggering Range	INT: 20 Hz to 10 MHz (min. 1 cm deflection as measured on cathode ray tube). EXT: DC ~ 10 MHz

Video Sync

Vertical and horizontal sync separator circuit provided so that any portion of composite video waveform can be synchronized and expanded for viewing. Polarity for VIDEO sync selected by SYNC switch. LINE (horiz.) and FRAME (vert.) sync switched automatically by SWEEP TIME/CM switch.

FRAME = 0.5 SEC/cm to 0.1 mSEC/cm (vertical sync pulses).

LINE = 50 μSEC/cm to 1 μSEC/cm (horizontal sync pulses).

HORIZONTAL AMPLIFIER (Horizontal Input through H INPUT jack).

Deflection Factor	150mV/cm or less.
Frequency Response	DC to 1 MHz (-3 dB).
Input Resistance	100 kΩ (nominal).
Input Capacity	35 pF or less.
Maximum Input Voltage	300 V (DC + AC peak) or 600 V p-p.

-X-Y- Y (vertical) signal supplied to scope INPUT jack; X (horizontal) signal supplied to H INPUT jack.

CALIBRATION VOLTAGE

1 V p-p square wave (±5%) at line frequency.

INTENSITY MODULATION

Voltage TTL logic compatible.
High logic - increases brightness.
Low logic - decreases brightness.

Input Resistance 10 kΩ (nominal).

POWER REQUIREMENTS

Input 120 or 240 VAC, ±10%, 50/60 Hz, 20 watts. (3-wire line cord, CSA approved for oscilloscopes.) Calibration accuracy applies over full input voltage range.

PROBES

Attenuation	Combination 10:1 and direct.
Input Impedances	10:1, 10 megohms, _____ Direct, 1 megohm
Connector	BNC.

SPECIFICATIONS

Model 1476

VERTICAL AMPLIFIERS (CH A and CH B)

Deflection Factor	0.01 V/cm to 20 V/cm in 11 calibrated ranges in 1-2-5 sequence. Variable between ranges.
Calibration Accuracy	± 5% on all ranges.
Frequency Response	DC: DC to 10 MHz (-3 dB) AC: 2 Hz to 10 MHz (-3 dB).
Risetime	35 nanoseconds.
Overshoot	3% or less at 100 kHz squarewave display.
Ringing	3% or less at 100 kHz squarewave display.
Input Resistance	1 megohm, ± 5%.
Input Capacity	22 pF (±3 pF).
Max. Input Voltage	300 V (DC + AC peak) or 600 V P-P.
Operating Modes	Channel A only. Channel B only. Dual-trace automatically chopped at all sweep times of 1 mS/cm and slower; alternate trace automatically selected for all faster sweep times.
Chop Frequency	200 kHz (± 20%).
Channel Separation	Better than 60 dB @ 1 kHz.

SWEEP CIRCUITS (Common to CH A and CH B)

Sweep System	Triggered and automatic. In automatic mode, sweep is obtained without input signal.
Sweep Time	1 μSEC/cm to 0.5 SEC/cm in 18 calibrated ranges, in 1-2-5 sequence. Variable between ranges.
Sweep Time Accuracy	± 5%.
Sweep Magnification	Obtained by enlarging the above sweep 5 times from center. Maximum sweep speed becomes 0.2 μSEC/cm.
Horizontal Linearity	3% or less distortion.

TRIGGERING

Source	INT and EXT (1 V p-p sensitivity). MODE switch selects source of internal trigger; the CH A signal is the triggering source in the CH A and DUAL modes, and the CH B signal is the triggering source in the CH B mode.
Slope	Positive and negative, continuously variable level control; pull for AUTO.
Triggering Range	INT: 20 Hz to 10 MHz (min. 1 cm deflection as measured on cathode ray tube). EXT: DC to 10 MHz.

Video Sync

Vertical and horizontal sync separator circuit provided so that any portion of composite video waveform can be synchronized and expanded for viewing. LINE (horiz.) and FRAME (vert.) sync switched automatically by SWEEP TIME/CM switch.
FRAME = 0.5 SEC/cm to 0.1 mSEC/cm (vertical sync pulses).
LINE = 50 μSEC/cm to 1 μSEC/cm (horizontal sync pulses).

HORIZONTAL AMPLIFIER (Horizontal Input through CH B Input)

Deflection Factor	.01 V/cm to 20 V/cm.
Frequency Response	DC to 1 MHz (-3 dB).
Input Resistance	1 megohm (nominal).
Input Capacity	22 pF (±3 pF).
Maximum Input Voltage	300 V (DC + AC peak) or 600 V P-P.
X-Y Operation	With SWEEP TIME/CM switch in CH B position, the CH A input becomes the Y input (vertical) and the CH B input becomes the X input (horizontal). The CH B position control becomes the horizontal position control.

CALIBRATION VOLTAGE

1 V p-p square wave (± 5%) at line frequency.

INTENSITY MODULATION

Voltage	TTL logic-compatible, high logic — increases brightness; low logic — decreases brightness.
Input Resistance	10 kΩ (nominal).

POWER REQUIREMENTS

Input	120 or 240 V AC, ±10%, 50/60 Hz, 20 watts. (3-wire line cord, CSA-approved for oscilloscopes.) See Fig. 51.
-------	---

PROBES

Attenuation	Combination 10:1 and direct.
Input Impedances	10:1 = 10 megohms, Direct = 1 megohm,
Connector	BNC

OPTIONAL ACCESSORIES

The following **B & K-PRECISION** accessories are available to complement your Model 1476 Oscilloscope.

MODEL LC-74 PROTECTIVE COVER

This rugged grained leatherette cover provides convenience and protection when transporting the oscilloscope. A handy pocket provides stowage for probes.

MODEL RM-14 RACK MOUNTING KIT

This kit includes everything needed to mount the oscilloscope in a standard 19" rack, including panel, hardware, and complete instructions.

INSTRUMENT CONNECTING CABLES

The following **B & K-PRECISION** cables, which may be purchased separately, may be useful for connecting your oscilloscope directly to other equipment:

Model CC-41. 36" RG/58U with a BNC connector on each end.

Model CC-42. 36" RG/58U with BNC connector and UHF connector (PL-259).

Model CC-43. 36" RG/58U with BNC connector and banana plugs.

Model CC-44. 36" RG/58U connector and coaxial microphone connector.

Model CC-45. 36" RG/58U with BNC connector and type N connector.

MODEL PR-32 RF DEMODULATOR PROBE

This probe permits display and analysis of the modulation envelope of RF signals to 250 MHz (-6 dB @ 250 MHz). Input impedance is 30 k Ω minimum, shunted by 4.5 pF maximum. Internal shielding protects against stray RF pickup.

MODEL PR-37 DELUXE PROBE

The **B & K-PRECISION** Model PR-37 deluxe probe is designed for use with wideband oscilloscopes to 100 MHz. The PR-37 is a slim-body probe of precision lightweight construction. A three-position switch select 10:1 or direct modes, or a reference position that grounds the tip through a 9M resistor. The 52" coaxial cable is extremely flexible. Accessories included with the PR-37 are a spring-loaded retractable tip cover, insulating tip BNC tip adapter, IC tip and an insulated compensation capacitor adjustment tool. The insulating tip is designed for probing dense solid-state circuitry with no danger of shorting nearby components.

The BNC adapter tip converts the probe tip into a push-on BNC fitting, ideal for interface with test points or output jacks. The IC tip guides the probe contact into any pin of a standard DIP, making it almost impossible to short two pins of an IC. The PR-37 is available in both grey and red colors. Probes of different colors are particularly useful with a dual-trace scope for instant identification of the channel to which a probe is connected. The PR-37 and accessories come in convenient zippered vinyl case. Model PR-37G is grey and PR-37R is red.

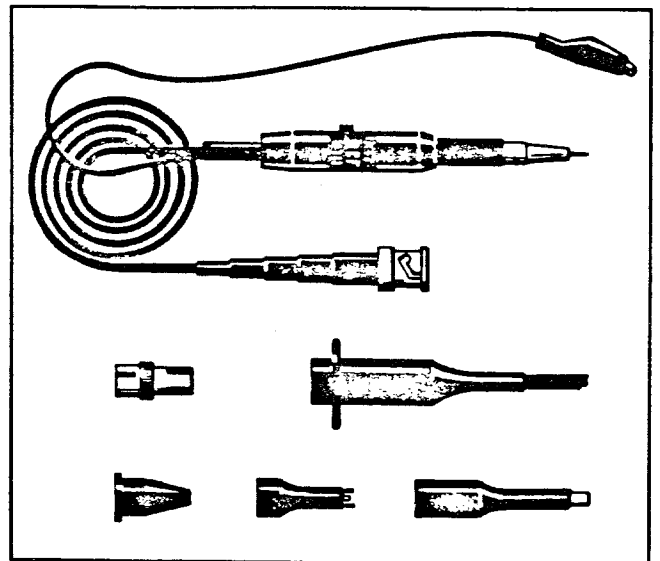

CONTROLS AND INDICATORS

1. Pilot lamp. Lights when oscilloscope is on.
2. SWEEP TIME/CM switch. Horizontal coarse sweep time selector. Selects calibrated sweep times of 1 μ SEC/cm in 18 steps when VARIABLE/HOR GAIN control 3 is set to CAL. EXT-H position disables internal sweep generator and displays external horizontal input.
3. VARIABLE/HOR GAIN control. Fine sweep time adjustment (horizontal gain adjustment when SWEEP TIME/CM switch. 2 is in EXT H position). In the extreme clockwise position (CAL) the sweep time is calibrated.
4. CAL jack. Provides calibrated 1 Vp-p square wave output at line frequency (60 Hz).
5. \blacktriangleleft POSITION control. Rotation adjusts horizontal position of trace. Push-pull switch selects 5X magnification when pulled out; normal when pushed in.
6. TRIG LEVEL control. Sync level adjustment determines point on waveform slope where sweep starts; (-) equals most negative point of triggering and (+) equals most positive point of triggering. Push-pull switch selects automatic triggering when pulled out (PULL AUTO). When automatic triggering, a sweep is generated even without an input signal.
7. HOR INPUT jack. Input terminal for external horizontal signal.
8. SYNC switch. Four-position lever switch with the following positions:

SLOPE. The SLOPE positions are used for viewing all waveforms except television composite video signals.

(+) Sweep is triggered on positive-going slope of waveform.

(-) Sweep is triggered on negative-going slope of waveform.

VIDEO. In the VIDEO positions, the sync pulses of a composite video signal are used to trigger the sweep; the vertical sync pulses (frame) are automatically selected for sweep times of 0.5 SEC/cm to 0.1 mSEC/cm, and horizontal sync pulses (line) are automatically selected for sweep times of 50 μ SEC/cm to 1 μ SEC/cm.

(+) Sweep is triggered on positive-going sync pulse.

(-) Sweep is triggered on negative-going sync pulse.
9. GND terminal. Chassis ground.
10. SOURCE switch.

INT: waveform being observed is used as sync trigger.

EXT: signal at EXT TRIG jack 11 is used as sync trigger.
11. EXT TRIG jack. Input terminal for external sync.
12. \blacktriangle POSITION control. Rotation adjusts vertical position of trace.
13. INPUT jack. Vertical input.
14. AC-GND-DC switch. Vertical input selector switch.

AC position: blocks DC component of input signal.

GND position: opens signal input path and grounds input to vertical amplifier. This provides a zero-signal base line, the position of which can be used as a reference when performing DC measurements.

DC position: direct input of AC and DC component.
15. VOLTS/CM switch. Vertical attenuator. Coarse adjustment of vertical sensitivity. Vertical sensitivity is calibrated in 11 steps from .01 to 20 volts per cm when VARIABLE 16 is set to the CAL position.
16. VARIABLE control. Vertical attenuator adjustment. Fine control of vertical sensitivity. In the extreme clockwise (CAL) position, the vertical attenuator is calibrated.
17. FOCUS control.
18. POWER OFF/INTENSITY control. Fully counterclockwise turns off oscilloscope. Clockwise turns on oscilloscope and increases brightness of trace.
19. Cathode Ray Tube (CRT). This is the screen on which the waveforms are viewed.
20. Scale. Provides calibration marks for voltage and time measurements.
21. Vector overlay. Used for vectorscope applications. (Not illustrated.)
22. Probe. Combination 10:1 attenuation and direct measurement probe for vertical input. (Not illustrated.)
23. Combination feet and cord wrap (quantity of 4).
24. INT MOD jack. Intensity modulation (Z axis) input.
25. Power cord.
26. DC BAL. Balance adjustment for vertical amplifier.
27. CRT rotation adjustment.

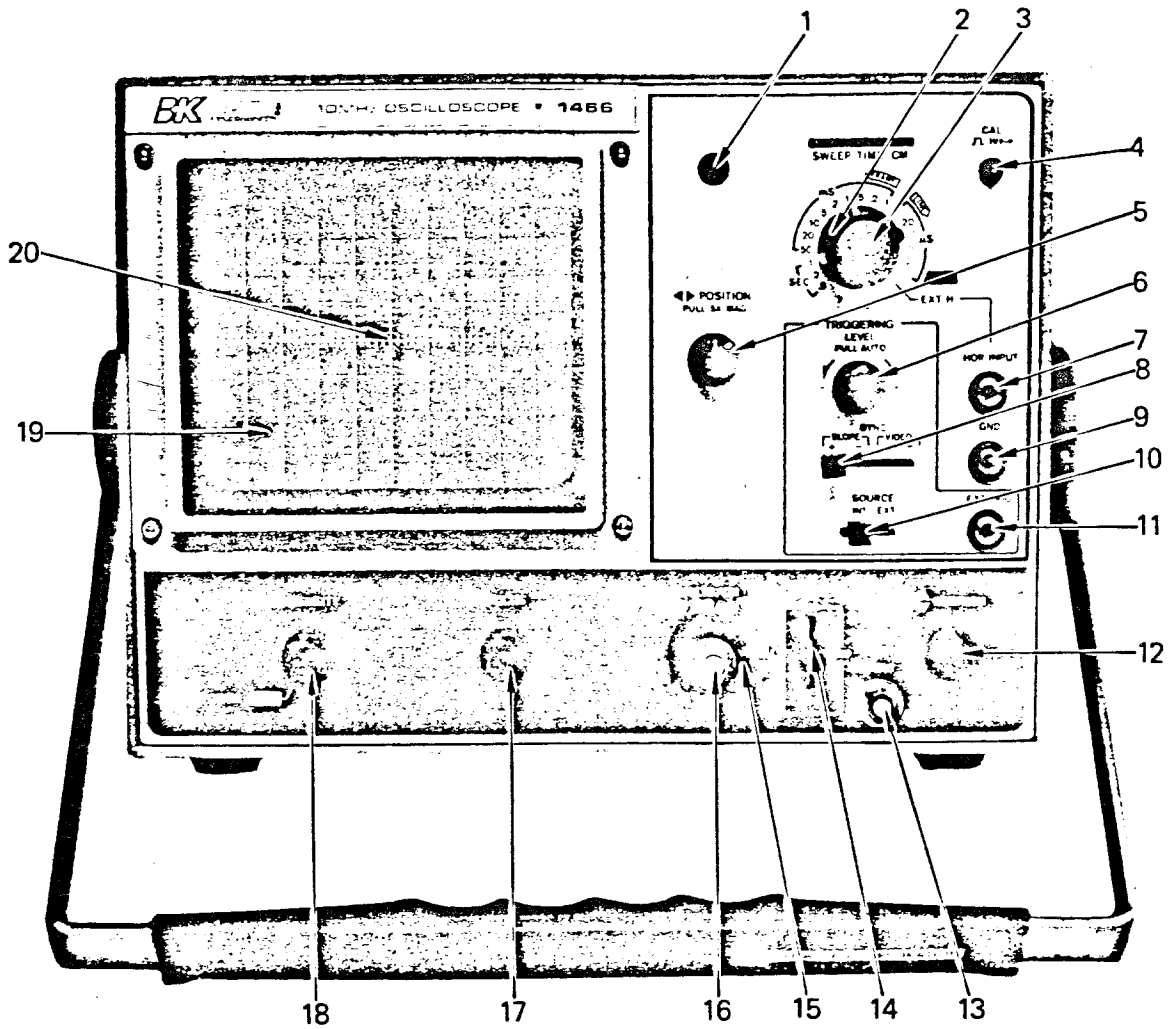

Fig. 1. Controls and indicators.

Model 1466

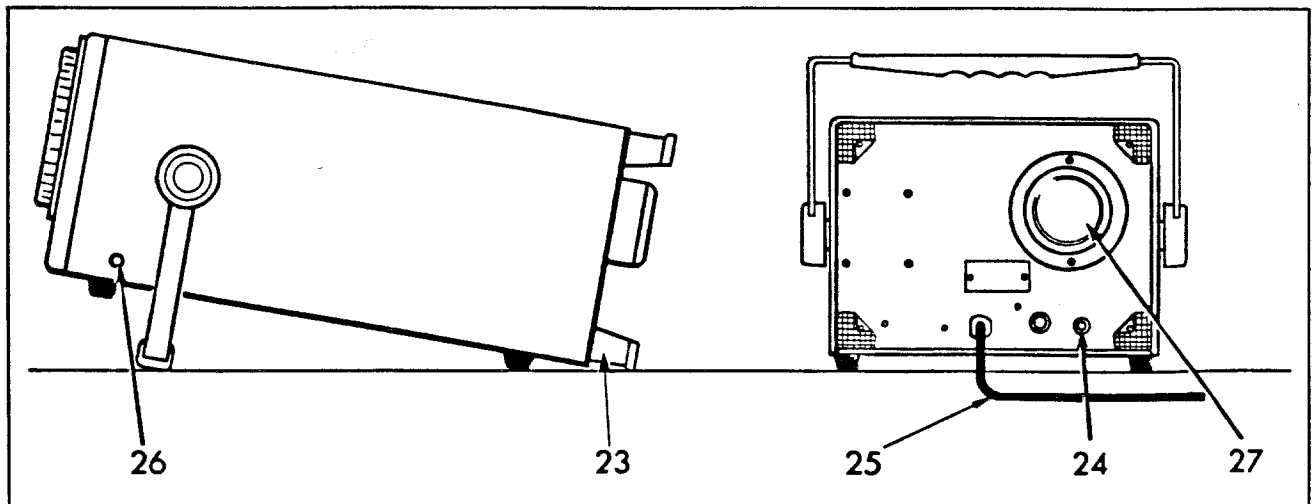

Fig. 2. Rear and side panel facilities.

OPERATOR'S CONTROLS, INDICATORS AND FACILITIES

1. **Cathode Ray Tube (CRT).** This is the screen on which the waveforms are viewed.
2. **Scale.** The 8 x 10 cm graticule provides calibration marks for voltage (vertical) and time (horizontal) measurements.
3. **Pilot Lamp.** Lights when oscilloscope is turned on.
4. **SWEEP TIME/CM Switch.** Horizontal sweep time selector. Selects calibrated sweep times of 1 μ SEC/cm (microsecond per centimeter) to 0.5 SEC/cm in 18 steps. In the CH B position, this switch disables the internal sweep generator and permits the CH B input to provide horizontal sweep.
5. **CAL 1 V P-P Terminal.** Provides calibrated 1 volt peak-to-peak square wave input signal at the line frequency. This is used for calibration of the vertical amplifier attenuators.
6. **◀▶ POSITION Control.** Rotation adjusts horizontal position of traces (both traces when operated in the dual trace mode). Push-pull switch selects 5X magnification when pulled out (PULL 5X MAG): normal when pushed in.
7. **TRIGGERING LEVEL Control.** Sync level adjustment determines points on waveform slope where sweep starts; (-) equals most negative point of triggering and (+) equals most positive point of triggering. Push-pull switch selects automatic triggering when pulled out (PULL AUTO). When automatic triggering, a sweep is generated even without an input signal.
8. **EXT TRIG Jack.** Input terminals for external trigger signal.
9. **SYNC Switch.** Four-position lever switch with the following positions.

SLOPE. The SLOPE positions are used for viewing all waveforms except television composite video signals.

(+) Sweep is triggered on positive-going slope of waveform.

(-) Sweep is triggered on negative-going slope of waveform.

VIDEO. In the VIDEO positions, the sync pulses of a television composite video signal are used to trigger the sweep; the vertical sync pulses (frame) are automatically selected for sweep times of 0.5 SEC/cm to 0.1 mSEC/cm, and horizontal sync pulses (line) are automatically selected for sweep times of 50 μ SEC/cm to 1 μ SEC/cm.

(+) Sweep is triggered on positive-going sync pulse.

(-) Sweep is triggered on negative-going sync pulse.
10. **SOURCE Switch.** Selects triggering source for the sweep.

INT Sweep is triggered by CH A signal when MODE switch is in CH A or DUAL position.

Sweep is triggered by Channel B signal when MODE switch is in CH B position.

EXT Sweep is triggered by an external signal applied at the EXT TRIG jack 8.
11. **Channel B POSITION Control.** Vertical position adjustment for Channel B trace. Becomes horizontal position adjustment when SWEEP TIME/CM switch 4 is in the CH B position.
12. **Channel B DC BAL Adjustment.** Vertical DC Balance adjustment for Channel B trace.
13. **Channel B INPUT Jack.** Vertical input jack of Channel B. Jack becomes external horizontal input when SWEEP TIME/CM switch 4 is in the CH B position.
14. **Channel B DC-GND-AC Switch.**

DC Direct input of AC and DC component of input signal.

GND Opens signal path and grounds input to vertical amplifier. This provides a zero-signal base line, the position of which can be used as a reference when performing DC measurements.

AC Blocks DC component of input signal.
15. **Channel B. VOLTS/CM Switch.** Vertical attenuator for Channel B. Vertical sensitivity is calibrated in 11 steps from .01 to 20 volts per cm. This control adjusts horizontal sensitivity when the SWEEP TIME/CM switch 4 is in the CH B position.
16. **MODE Switch.** Three-position lever switch; selects the basic operating modes of the oscilloscope.

CH A Only the input signal to Channel A is displayed as a single trace.

DUAL Dual-trace operation; both the Channel A and Channel B input signals are displayed on two separate traces.

CH B Only the input signal to Channel B is displayed as a single trace.
17. **Channel A VOLTS/CM Switch.** Vertical attenuator for Channel A. Vertical sensitivity is calibrated in 11 steps, from .01 to 20 volts per cm.
18. **Channel A DC-GND-AC Switch.**

DC Direct input of AC and DC component of input signal.

GND Opens signal path and grounds input to vertical amplifier. This provides a zero-signal base line, the position of which can be used as a reference when performing DC measurements.

AC Blocks DC component of input signal.
19. **Channel A INPUT Jack.** Vertical input jack of Channel A.
20. **Channel A DC BAL Adjustment.** Vertical DC balance adjustment for Channel A trace.
21. **Channel A POSITION Control.** Vertical position adjustment for Channel A trace.
22. **FOCUS Control.**
23. **INTENSITY Control.** Clockwise rotation increases the brightness of trace.
24. **POWER Switch.** Turns unit on and off.

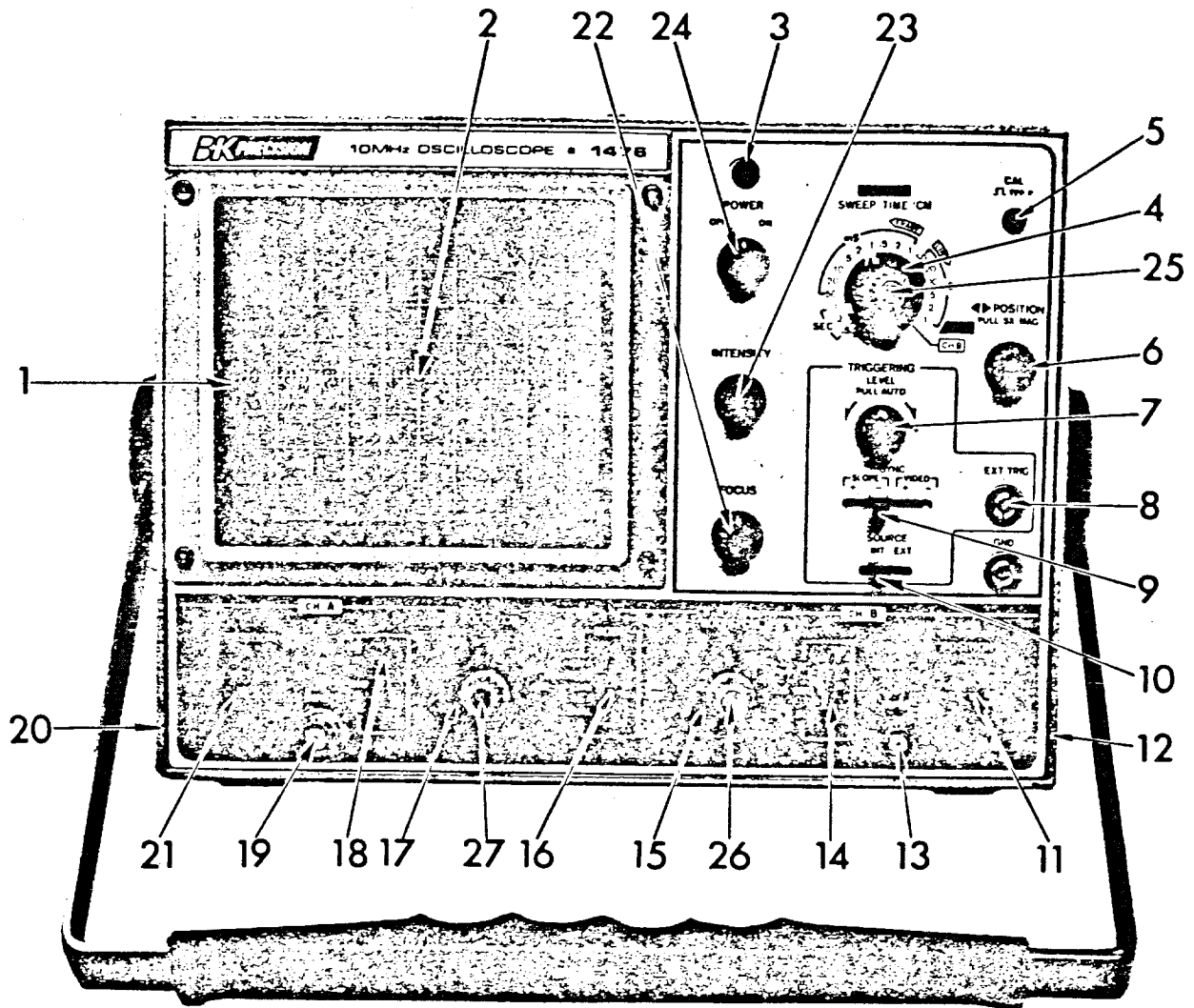

Fig. 1. Front panel controls and indicators.

Model 1476

- 25. **VARIABLE Control.** Fine sweep time adjustment. In the extreme clockwise position (CAL), the sweep time is calibrated.
- 26. **CH B VARIABLE Control.** CH B vertical attenuator adjustment. Fine control of CH B vertical sensitivity. In the extreme clockwise (CAL) position, the vertical attenuator is calibrated.
- 27. **CH A VARIABLE Control.** CH A vertical attenuator adjustment. Fine control of CH A vertical sensitivity. In the extreme clockwise (CAL) position, the vertical attenuator is calibrated.
- 28. **INT MOD Jack.** Intensity modulation (Z-axis) input.
- 29. **AC Line Cord (See Fig. 2).** CSA-approved for oscilloscopes.
- 30. **Probe (See Fig. 3).** The B & K-Precision Model PR-31 combination 10 : 1/Direct probes have been designed for use with this oscilloscope. However, any probe designed for use with an oscilloscope having a nominal input impedance of 1 megohm shunted by 35 pF and capable of operation up to 10 MHz, can be used.
- 31. **Vector Overlay (Not Shown).** Interchanges with scale for vectorscope operation.

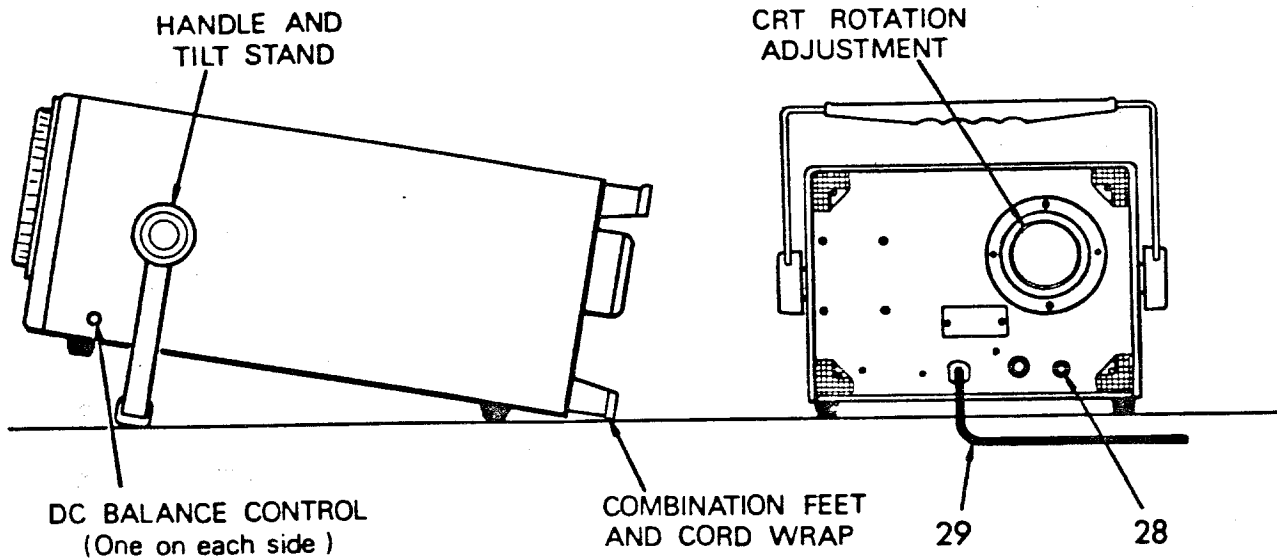

Fig. 2. Rear and side panel facilities.

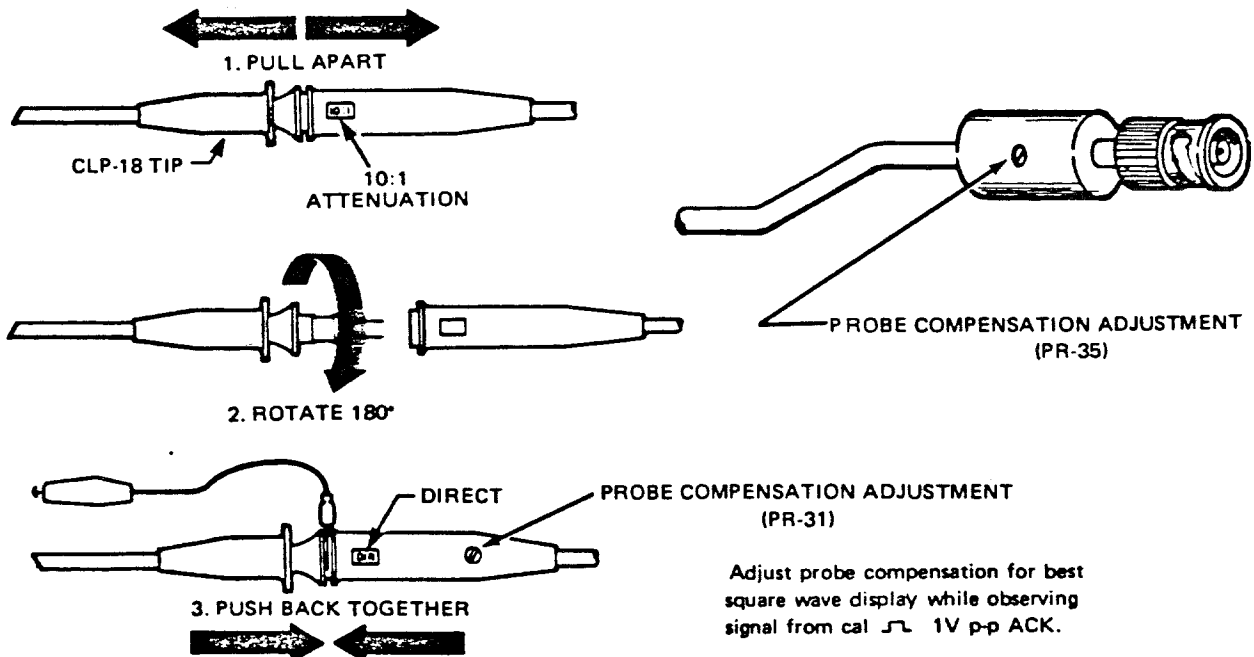

Fig. 3. Probe details.

CIRCUIT DESCRIPTION

The block diagram of Fig. 40 outlines the circuit breakdown of the oscilloscope. Circuit details are obtained by reference to the schematic diagram.

VERTICAL AMPLIFIER

The signal to be displayed is applied to the VERT INPUT jack j1 and passes through the input attenuator section. Attenuation values of X1, X10, X100 and X1000 are selected by VOLTS/CM switch S104.

The input signal is then applied to the vertical preamplifier stage. Q121, a dual FET, forms a balanced differential amplifier input stage with output signals of opposite polarity. VR111 is the side panel DC BALANCE control. Emitter followers Q123 and Q124 drive differential amplifier Q125 and Q126. Stage gain is changed at the emitters of Q125 and Q126 by S104 to provide fixed gains of 5, 2, and 1. Variable control VR115 adjusts the signal level to the inputs of Q403 and Q404 while VERTICAL POSITION, VR112, and amplifier calibration VR113 are accomplished at the emitters of Q143 and Q144.

The vertical amplifier stage consists of transistors Q109 through Q120, which amplifies the signal to the levels required to drive the vertical deflection plates of the CRT. VR105 is the trace centering adjustment, while VR104 and TC113 are high-frequency compensation adjustments.

Transistors Q127 and Q128 form the TRIGGER AMPLIFIER which provides a sample of the vertical signal to the sync amplifier for internal triggering.

SYNC AMPLIFIER AND INVERTER

Source switch S303 selects either INTERNAL (from preamplifiers) or EXTERNAL triggering. The trigger signal is then fed to differential amplifier IC305. Either the inverted (SLOPE-) or non-inverted (SLOPE+) signal is selected by SYNC switch S304. LEVEL control VR310 adds a DC component to the output of IC305.

SYNC SEPARATOR

When VIDEO + or - is selected, the output of IC305 is routed to the SYNC SEPARATOR circuit consisting of Q320 and Q319. Q320 is held at cutoff by a negative voltage developed across C332 corresponding to an average value of the input signal. Positive-going pulses drive Q320 out of cutoff. The output of Q320 corresponds to the sync tips of the composite video signal.

When in the FRAME positions of the SWEEP TIME/CM switch (.1mS to .5 SEC), Q319 is on; this allows C331 to filter out the horizontal sync pulses, permitting only vertical sync pulses to pass to the sweep circuit. In the LINE positions (50 μ SEC to 1 μ SEC), Q319 is turned off, removing C331 and allowing horizontal sync pulses to pass to the sweep circuit.

SWEEP CIRCUIT

The trigger signal passes through emitter follower Q303, and to the SCHMITT TRIGGER circuit consisting of two gates of IC303. The output pulses from IC303 clock the SWEEP CONTROL flip-flop IC301. On the negative edge of the clock waveform, the Q output of IC301 goes low, turning off Q307 to initiate the sweep.

Transistors Q308 and Q309 and the timing capacitors and resistors selected by the SWEEP TIME/CM switch, form a MILLER INTEGRATING circuit to provide a linear ramp voltage. The sweep ramp from the collector of Q309 is fed to PIN 6 of HOLDOFF TIMER IC302. The output of IC302 holds Q307 on through IC301 to prevent the sweep from starting until the retrace is complete. The holdoff time is determined by capacitors C309, C310, and C311.

As soon as the Q output of IC301 goes low, the reset of IC301 is held low by IC303 to exclude any new clock pulses until the sweep ramp is terminated. When the sweep ramp exceeds the level set by VR309 (SWEEP LENGTH), IC302 places a low on the set input of IC301. A low on the set input forces the Q output of IC301 high which turns on Q307, terminating the sweep.

AUTO SWEEP

Transistors Q304, Q305, and Q306 form the AUTO SWEEP circuit. When the trigger level control is pulled out (AUTO) and no signal is present at the trigger amplifier, C303 charges and turns Q306 on; this places a low on the reset of IC301 and allows a sweep to recirculate at a rate determined by the resistor and capacitor selected by the SWEEP TIME/CM switch. When a trigger signal is present, transistors Q304 and Q305 discharge C303, turning Q306 off and enabling the sweep to trigger on the incoming signal.

HORIZONTAL AMPLIFIER

The sweep ramp from the collector of Q309 is applied through VR306 (TIMING ADJ.) to the input of the horizontal amplifier consisting of Q314, Q315, Q317, and Q318. VR305 is a horizontal centering adjustment and VR307 is the horizontal position control.

The output of transistors Q317 and Q318 is applied to the horizontal deflection plates of the CRT. VR303 is the X5 magnification adjustment and VR304 is the magnification centering adjustment.

1 VOLT CAL SIGNAL

Transistors Q301 and Q302 provide a 60 Hz square wave. VR212 adjusts the amplitude of the CAL SIGNAL.

POWER SUPPLY

The power supply provides all voltages necessary for operating the oscilloscope.

Regulated output voltages of +10, -8, and +5 are provided for all logic and amplifier circuits. Amplifier output stages require the 180V.

The accelerating voltage for the CRT is derived from a DC-to-DC converter consisting of Q142 and T101. The output of T101 is rectified and filtered and applied through voltage dividers to the CRT. A portion of the high voltage is fed to a regulator circuit consisting of Q129 and Q130 to provide a constant accelerating potential under varied operating conditions.

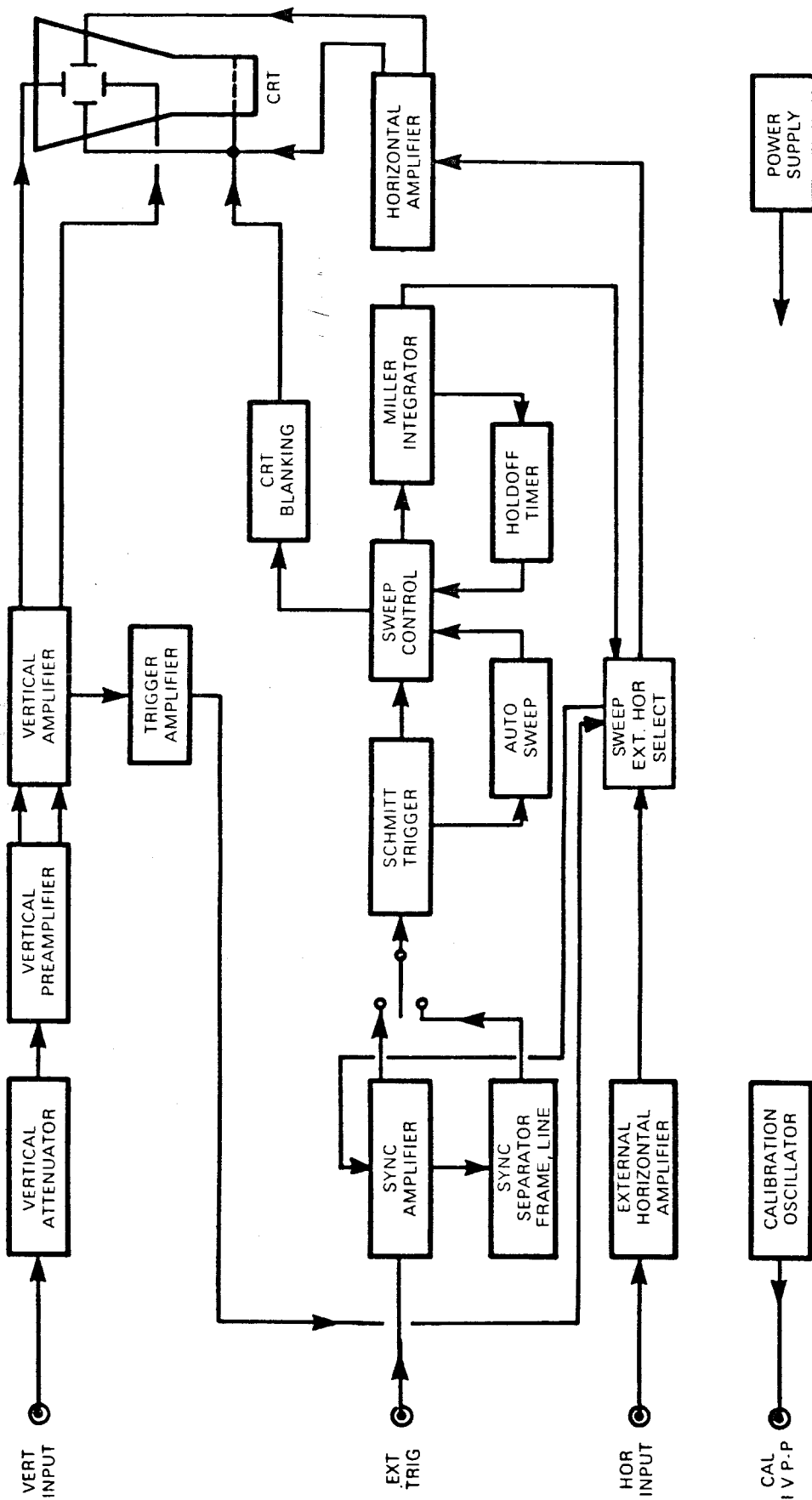

Fig. 40. Block diagram of Model 1466 oscilloscope.

CIRCUIT DESCRIPTION

The block diagram, Fig. 50, outlines the circuit breakdown of the oscilloscope. Circuit details are obtained by reference to the schematic diagram.

GENERAL

Basically, the oscilloscope consists of two identical vertical preamplifiers, each having its own input attenuator network. The outputs of the vertical preamplifiers can be switched, as desired, into the main vertical amplifier. The switching of the CH A and CH B preamplifiers is determined by the position of the MODE switch and MODE LOGIC. The main vertical amplifier feeds the VERTICAL OUTPUT AMPLIFIER, which drives the vertical deflection plates of the CRT.

Horizontal deflection is provided by the horizontal amplifier. Drive to the horizontal amplifier is furnished by calibrated sweep speed circuits or by the signal from the CH B preamplifier when X-Y operation is selected.

All supply voltages are fully regulated and a DC-to-DC converter provides a regulated, 2kV, accelerated potential to the CRT.

VERTICAL PREAMPLIFIERS

Channel A and Channel B preamplifiers contain identical circuitry and circuit operation is the same for both. CH A will be described below.

The vertical preamplifier consists of dual FET input transistor Q101 which forms a balanced differential amplifier with output signals of opposite polarity. VR101 is the side panel DC BAL control. Emitter followers Q103 and Q104 drive the differential amplifier Q105 and Q106. Stage gain is changed in the emitters of Q105 and Q106 to provide gains of 5, 2, and 1. The front panel POSITION control VR102 provides a DC component to move the trace vertically across the screen.

Transistor array IC101 is turned on or off by the MODE LOGIC circuitry.

Trigger amplifier Q107 and Q108 buffers the signal from IC101 and delivers the signal to the trigger amplifier.

MODE LOGIC

The mode of operation (CH A, CH B, and DUAL) is controlled by IC103 and IC104. When CH A is selected by the front panel MODE switch, the Q output of IC103 goes LOW, turning on the CH A preamplifier and trigger amplifier. When CH B is selected the Q output of IC103 goes low turning on the CH B preamplifier and trigger amplifier. When DUAL is selected the Q and Q outputs of IC103 are switched on and off at a 200 kHz rate for the CHOPPED mode, and after each sweep when in ALTERNATE mode. When in DUAL, the CH A trigger amplifier is turned on, providing a trigger signal to the sweep circuits.

When the SWEEP TIME/CM switch is in CH B position, the CH B trigger amplifier signal is applied to the horizontal amplifier.

VERTICAL AMPLIFIER

The selected signal from the preamplifiers is applied to the vertical output stage consisting of transistors Q113 to

Q120, which amplifies the signal to the levels required to drive the vertical deflection plates of the CRT. VR105 is a DC balance control, while VR104 and TC113 are high-frequency compensation adjustments.

TRIGGER CIRCUIT

The trigger source, either CH A or CH B, is selected by MODE switch S105. Selecting either CH A or DUAL enables trigger amplifier Q107 and Q108, and CH B enables trigger amplifier Q127 and Q128. The trigger amplifier output is fed thru transistor switch Q313. Q313 is turned on in all positions of the SWEEP TIME/CM switch except CH B.

SYNC AMPLIFIER AND INVERTER

Source switch S303 selects either INTERNAL (from preamplifiers) or EXTERNAL triggering. The trigger signal is then fed to differential amplifier IC305. Either the inverted (SLOPE-) or non-inverted (SLOPE+) signal is selected by SYNC switch S304. LEVEL control VR310 adds a DC COMPONENT to the output of IC305.

SYNC SEPARATOR

When VIDEO+ or - is selected, the output of IC305 is routed to the SYNC SEPARATOR circuit consisting of Q320 and Q319. Q320 is held at cutoff by a negative voltage developed across C332 corresponding to an average value of the input signal. Positive-going pulses drive Q320 out of cutoff. The output of Q320 corresponds to the sync tips of the composite video signal.

When in the FRAME positions of the SWEEP TIME/CM switch (.1mS to .5 sec), Q319 is on; this allows C331 to filter out the horizontal sync pulses, permitting only vertical sync pulses to pass to the sweep circuit. In the LINE positions, 50μSEC to 1μSEC, Q319 is turned off, removing C331 and allowing horizontal sync pulses to pass to the sweep circuit.

SWEEP CIRCUIT

The trigger signal passes thru emitter follower Q303, and to the SCHMITT TRIGGER circuit consisting of two gates of IC303. The output pulses from IC303 clock the SWEEP CONTROL flip-flop IC301. On the negative edge of the clock waveform, the Q output of IC301 goes low, turning off Q307 to initiate the sweep.

Transistors Q308 and Q309 and the timing capacitors and resistors selected by the SWEEP TIME/CM switch, form a MILLER INTEGRATING circuit to provide a linear ramp voltage. The sweep ramp from the collector of Q309 is fed to the holdoff circuit IC302 and IC303.

As soon as the Q output of IC301 goes low, the reset of IC301 is held low by IC303 to exclude any new clock pulses until the sweep ramp is terminated. When the sweep ramp exceeds the level set by VR309 (SWEEP LENGTH), IC 302 places a low on the set input of IC301. A low on the set input forces the Q output of IC301 high which turns on Q307, terminating the sweep.

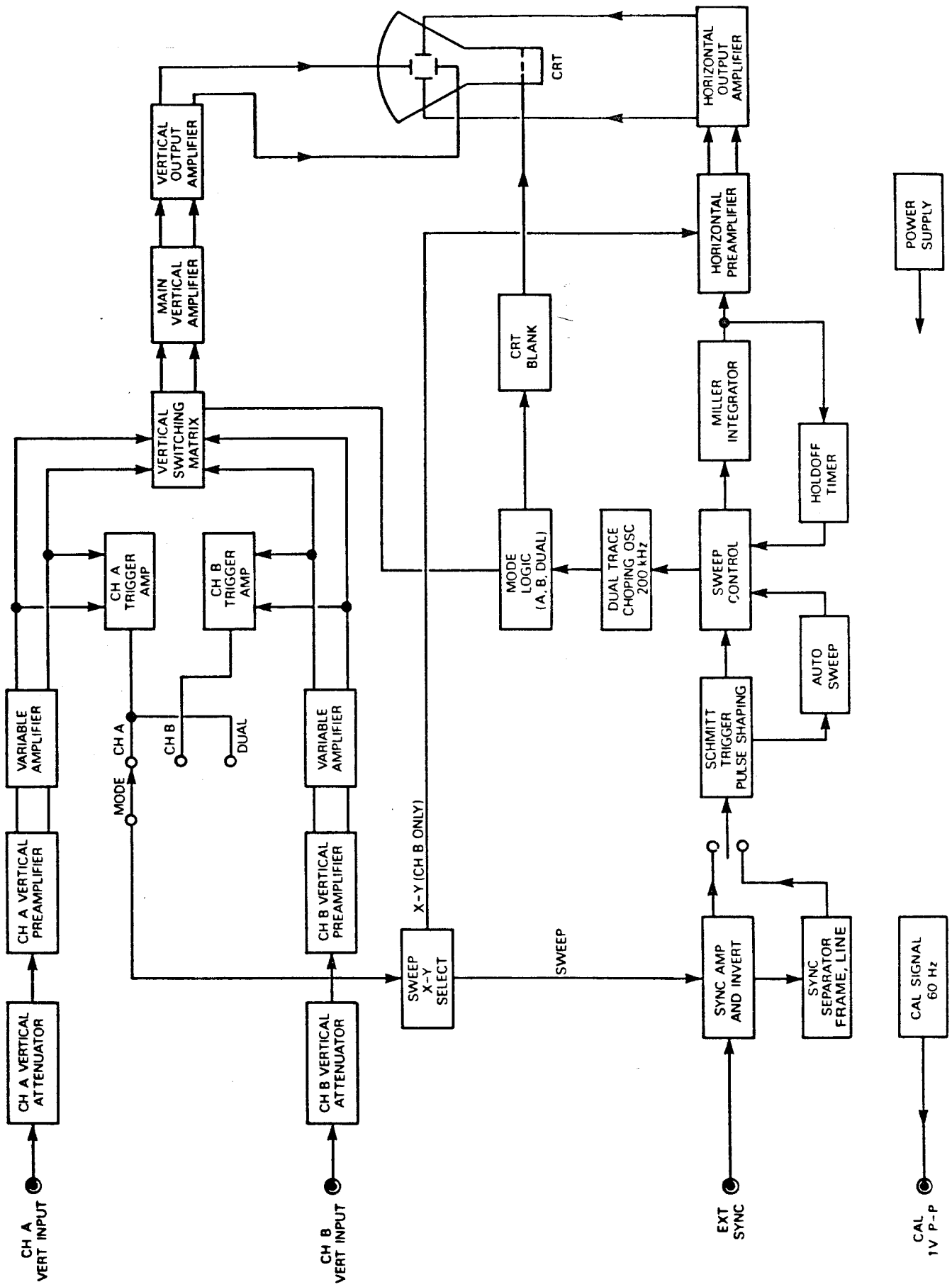

Fig. 50. Block diagram - Model 1476

AUTO SWEEP

Transistors Q304, Q305, and Q306 form the AUTO SWEEP circuit. When the trigger level control is pulled out (AUTO) and no signal is present at the trigger amplifier, C303 charges and turns Q306 on, this places a low on the reset of IC301 and allows a sweep to recirculate at a rate determined by the resistor and capacitor selected by the SWEEP TIME/CM switch. When a trigger signal is present, transistors Q304 and Q305 discharge C303, turning Q306 off and enabling the sweep to trigger on the incoming signal.

HORIZONTAL AMPLIFIER

The sweep ramp from the collector of Q309 is applied thru VR306 (timing adj.) to the input of the horizontal amplifier consisting of Q314, Q315, Q317, and Q318. VR305 is a horizontal centering adjustment and VR3 is the horizontal position control.

When in the X-Y mode, transistor Q313 is turned off thru IC303 and the CH B signal is applied to both Q312 and the horizontal amplifier. The output of transistors Q317 and Q318 is applied to the horizontal deflection plates of the CRT. VR303 is the X5 magnification adjustment and VR304 is the magnification centering adjustment.

CHOPPING OSCILLATOR

Two NAND gates from IC304 and IC305 form a 200 kHz CHOPPING OSCILLATOR activated in the CHOP positions of the SWEEP TIME/CM switch when DUAL is selected. IC304 provides a pulse for blanking the trace during retrace and when chopping.

1 VOLT CAL SIGNAL

Transistors Q301 and Q302 provide a 60 Hz square wave. VR301 adjusts the amplitude of the CAL SIGNAL.

POWER SUPPLY

The power supply provides all voltages necessary for operating the oscilloscope.

Regulated output voltages of +10, and -8, and +5 are provided for all logic and amplifier circuits. Amplifier output stages require the 180V.

The accelerating voltage for the CRT is derived from a DC-to-DC converter consisting of Q142 and T101. The output of T101 is rectified and filtered and applied thru voltage dividers to the CRT. A portion of the high voltage is fed to a regulator circuit consisting of Q129 and Q130 to provide a constant accelerating potential under varied operating conditions.

OPERATOR MAINTENANCE

WARNING

To prevent electric shock, do not perform servicing that requires removal of the covers unless you are qualified to do so. Exposed high voltage, up to 2000 volts is present when covers are removed. The operator maintenance procedures *do not* require removal of the top or bottom cover.

CRT ROTATION ADJUSTMENT

1. Loosen two screws on rear panel with adjustment slots.
2. Grasp cover and rotate to align horizontal trace with horizontal graticule line.
3. Tighten two screws.

DC BALANCE ADJUSTMENT

1. Adjust controls to obtain a horizontal trace. (CH A or CH B).
2. Adjust \blacklozenge POSITION control to center the trace vertically on the CRT.
3. Rotate the VOLTS/CM switch from 1V/CM to 2V/CM to 5V/CM while observing the trace.
4. If the trace moves vertically more than 5mm while performing STEP 3, adjust the CH A or CH B DC BAL (side panel screwdriver adjustment) so that the vertical movement of the trace does not exceed 5mm while performing STEP 3.

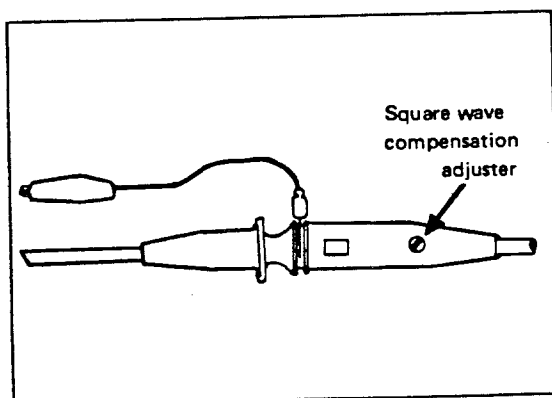

Fig. 4 Probe compensation adjuster

PROBE COMPENSATION

Probe compensation adjustment matches the probe to the input of scope. For best result, compensation of both should be adjusted initially, then the same probe always used with CH1 and CH2 respectively. Probe compensation should be readjusted whenever a probe from a different oscilloscope is used, or CH1 and CH2 probes are interchanged.

1. Connect probes to both V. INPUT terminal. Connect ground clip of probes to oscilloscope ground terminal and touch tips of both probes to CAL 1 kHz \square 1 V_{p-p} terminal.
2. Select signal trace operation of CH1 and CH2 for steps 3 and 4.
3. Set oscilloscope control to display 3 or 4 cycles of CAL square wave at 5 or 6 divisions amplitude.
4. Adjust compensation trimmer on probe for optimum square wave, waveshape (minimum overshoot, rounding off and tilt).

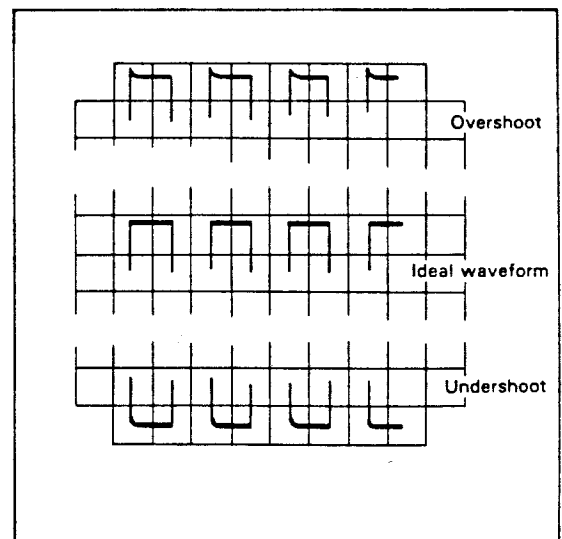

Fig. 5 Probe compensation adjuster

DISASSEMBLY

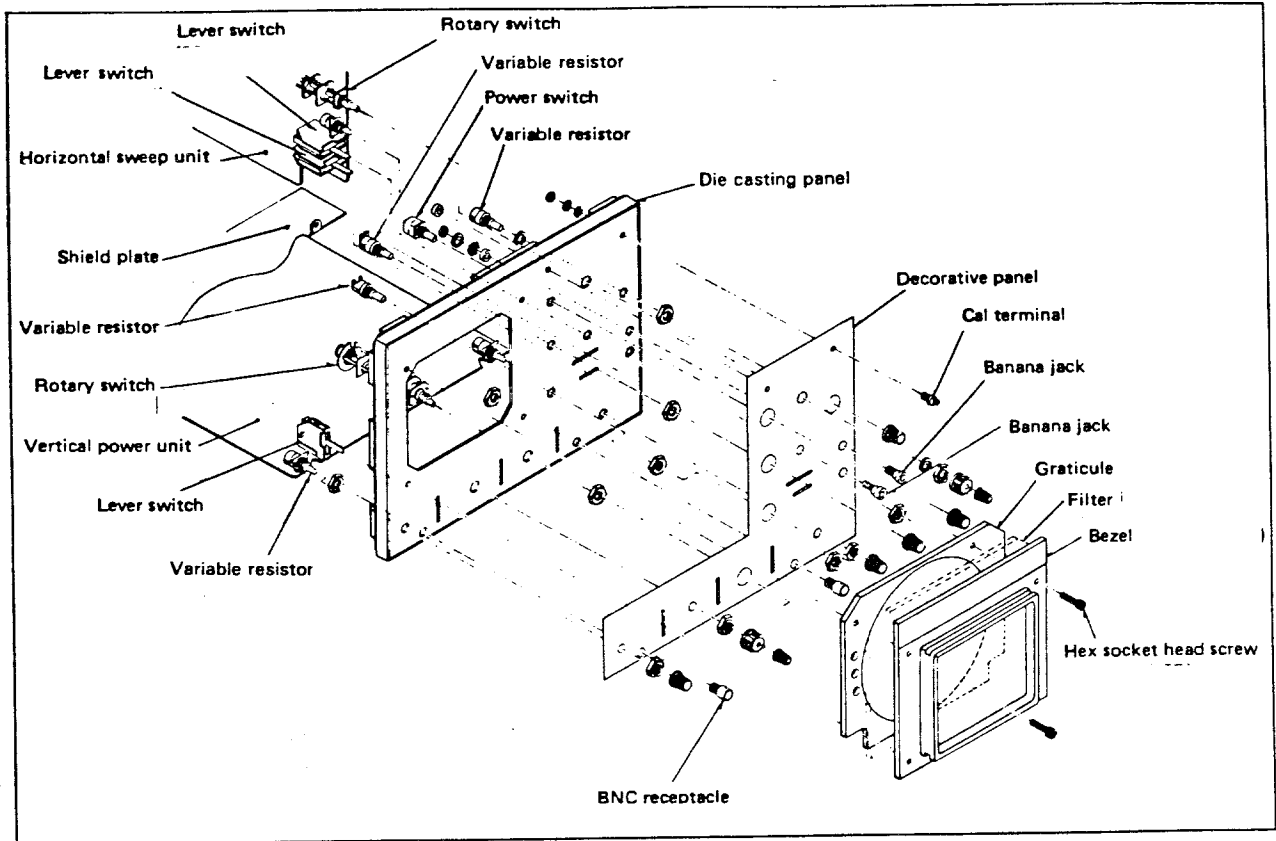

Fig. 6. Removing The CRT Bezel and Front Panel

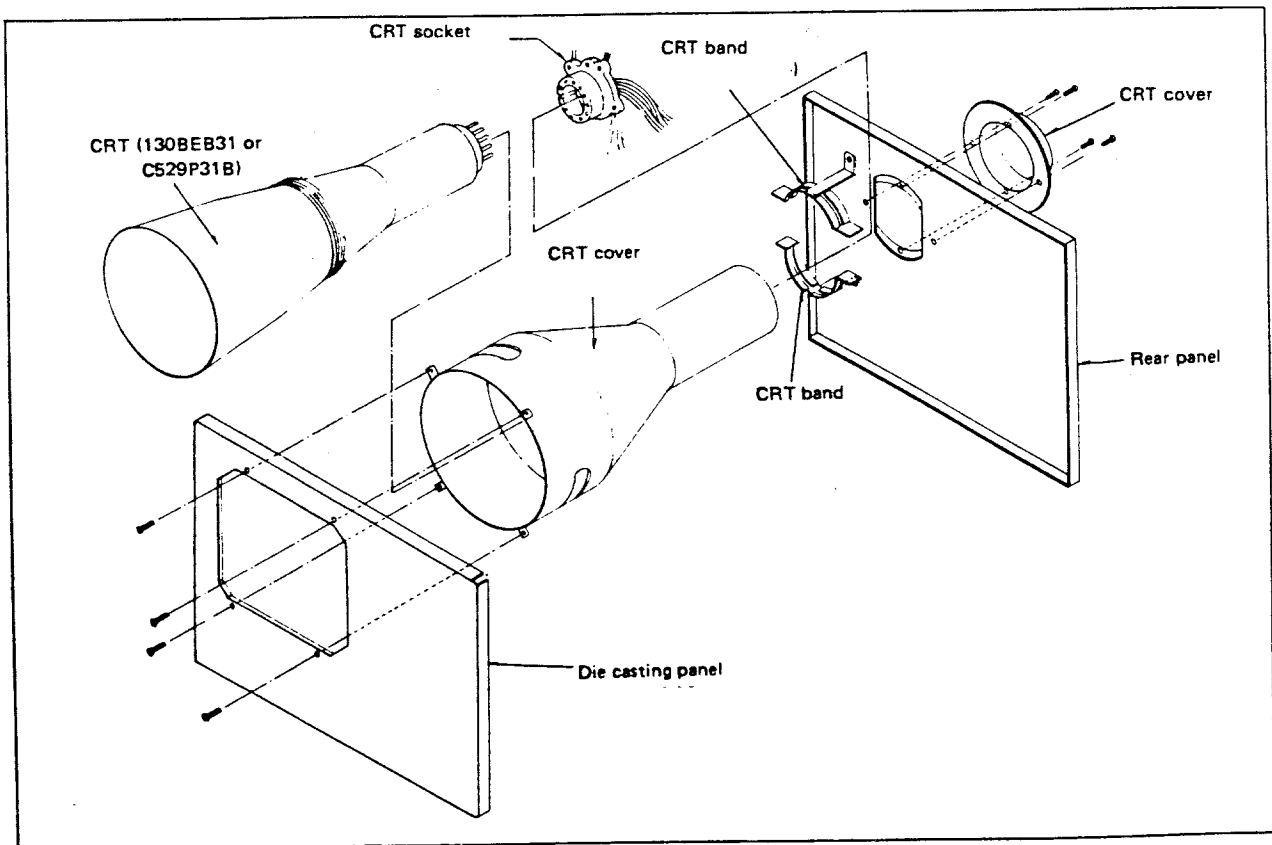

Fig. 7. Removing The CRT.

CALIBRATION

GENERAL

This oscilloscope was calibrated at the factory before shipment. Readjustment is recommended only if repairs have been made in a circuit affecting calibration, or if you have reason to believe the unit may be out of calibration. Complete calibration procedures are given in this manual. However, calibration adjustments should be attempted only if the proper test equipment is available, and you are experienced and qualified in its use. If the accuracy of the test equipment used for calibration is less than specified, the accuracy of the oscilloscope will be proportionately degraded. Perform related adjustments only in the specified sequence to prevent undesirable interaction of adjustments.

CALIBRATION CHECK

A general check of calibration accuracy may be made by displaying the output of the CAL 1 V P-P terminal on the screen of the oscilloscope. This signal provides a square wave of 1 volt peak-to-peak $\pm 5\%$ at line frequency (60 Hz in U.S.A.). This signal may be used for probe compensation adjustment and for an approximate check of amplitude accuracy. However, a signal source with amplitude and time accuracy of 1% or better should be used for performing calibration adjustments.

TEST EQUIPMENT REQUIRED

DC Voltmeter, 1% or better accuracy at 100 mV to 200 V (B & K-Precision Model 2815 or 2831 or equivalent).

High Voltage Multiplier Probe, 3% or better accuracy at 2 kV, input impedance 100 megohms or greater (B & K-Precision Model PR-28 or equivalent).

Sine and Square Wave Generator, 100 Hz to 100 kHz, amplitude variable from 10 mV to 10 V peak-to-peak, sine wave distortion 1% or less (B & K-Precision Model 3010 or 3020 or equivalent).

Fabricated RF oscillator, build per Fig. 14

Frequency Counter, 0.5% or better accuracy, 10 Hz to 10 MHz (any B & K-Precision Frequency Counter).

Oscilloscope Calibrator, amplitude accuracy of 0.5% or better at 1 kHz at peak-to-peak amplitude of 50 mV, 0.5 V, 5 V and 10 V, time marker accuracy of 0.5% or better at periods of 1 ms, 20 μ s, 0.5 μ s, 0.2 μ s, and 0.1 μ s. (Zi-Tech 303, Ballantine Model 6125, or Tektronix Model

PG-506 Calibration Generator, PG-501 Time Mark Generator and TM-500 Series Mainframe, or equivalent).

If oscilloscope calibrator is not available, the following group of instruments are suitable:

Sine Wave Generator, 1% or less distortion at 100 Hz to 100 kHz, 10 mV to 10 V peak-to-peak amplitude (B & K-Precision Model 3010 or 3020 or equivalent).

AC Voltmeter, 1% accuracy or better @ 1 kHz, 100 mV to 10 V ranges (B & K-Precision Model 2831 or equivalent).

Pulse or Square Wave Generator, 1 kHz to at least 5 MHz, peak-to-peak amplitude 50 mV to 10 V (B & K-Precision Model 3300 or equivalent).

Frequency Counter, 10 Hz to 10 MHz, 0.5% accuracy or better (any B & K-Precision Frequency Counter).

CALIBRATION ADJUSTMENTS

Preliminary

Make sure that line voltage is within 105-130 VAC limits (210-260 VAC for 240 VAC operation). Warm up the oscilloscope and calibrating instruments thoroughly (30 minutes) before starting. Perform adjustments in the specified sequence.

Calibration adjustment locations are shown in Fig. 8 thru 11, and the functions of each adjustment are summarized.

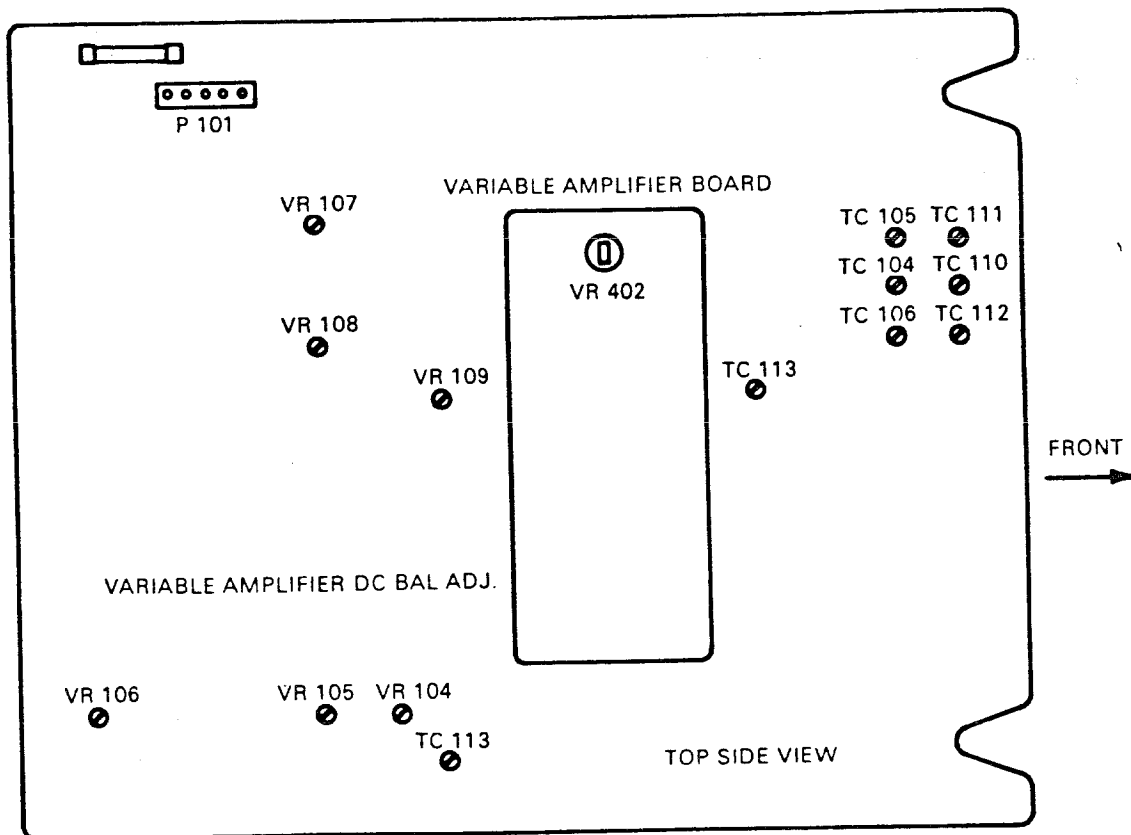

Fig. 8. Calibration location – vertical amplifier and power supply board. Model 1466

VR 104—HIGH FREQUENCY RESPONSE ADJ.
 VR 105—DISPLAY CENTER ADJ.
 VR 106—ASTIG.
 VR 107—1.9 KV ADJ.
 VR 108—INTENSITY ADJ.
 VR 109—180 V ADJ.
 VR 113 – VERTICAL ADJ.
 VR 402 – VARIABLE AMPLIFIER DC BAL ADJ.

TC 104—1/10 RANGE SQUARE WAVE ADJ.
 TC 105—1/100 RANGE SQUARE WAVE ADJ.
 TC 106—1/1000 RANGE SQUARE WAVE ADJ.
 TC 110—1/10 RANGE INPUT CAPACITY ADJ.
 TC 111—1/100 RANGE INPUT CAPACITY ADJ.
 TC 112—1/1000 RANGE INPUT CAPACITY ADJ.
 TC 113—MEDIUM FREQUENCY RESPONSE ADJ.

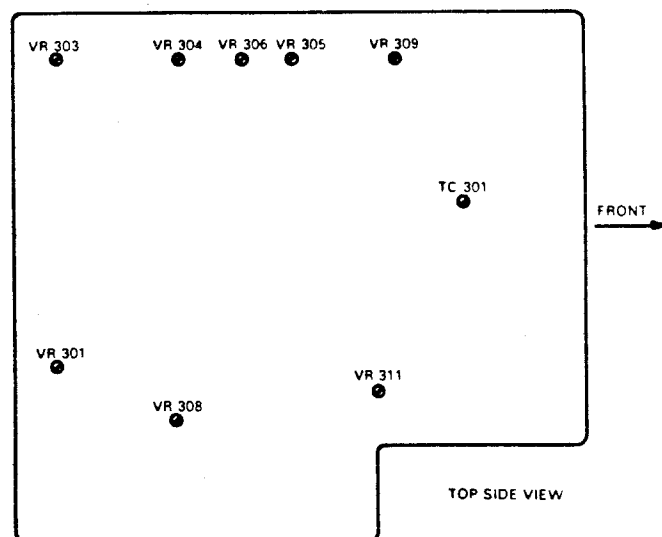
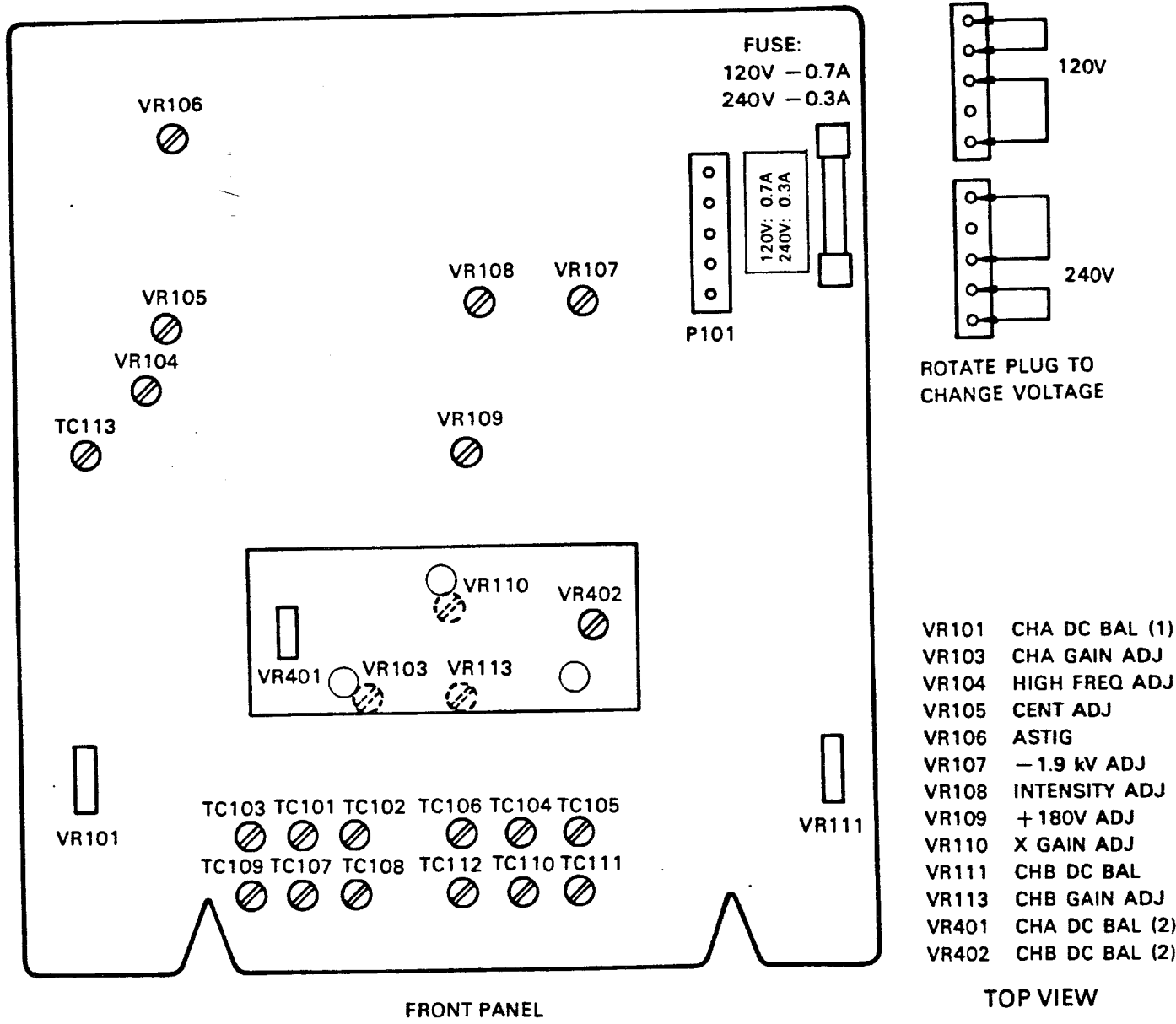

Fig. 9. Calibration location – horizontal amplifier board. Model 1466

VR 301—CAL VOLTAGE ADJ.
 VR 303—MAG ADJ.
 VR 304—MAG CENTER ADJ.
 VR 305—HORIZONTAL POSITION ADJ.
 VR 306—TIMING ADJ.

VR 308—EXT. HORIZONTAL POSITION ADJ.
 VR 309—SWEEP LENGTH
 VR 311—TRIGGER CENTER ADJ.
 TC 301—HIGH SPEED SWEEP (1 μ S—50 μ S) TIMING ADJ.



- VR101 CHA DC BAL (1)
- VR103 CHA GAIN ADJ
- VR104 HIGH FREQ ADJ
- VR105 CENT ADJ
- VR106 ASTIG
- VR107 -1.9 kV ADJ
- VR108 INTENSITY ADJ
- VR109 +180V ADJ
- VR110 X GAIN ADJ
- VR111 CHB DC BAL
- VR113 CHB GAIN ADJ
- VR401 CHA DC BAL (2)
- VR402 CHB DC BAL (2)

Fig. 10. Calibration diagram, vertical amplifier and power supply board.

Model 1476

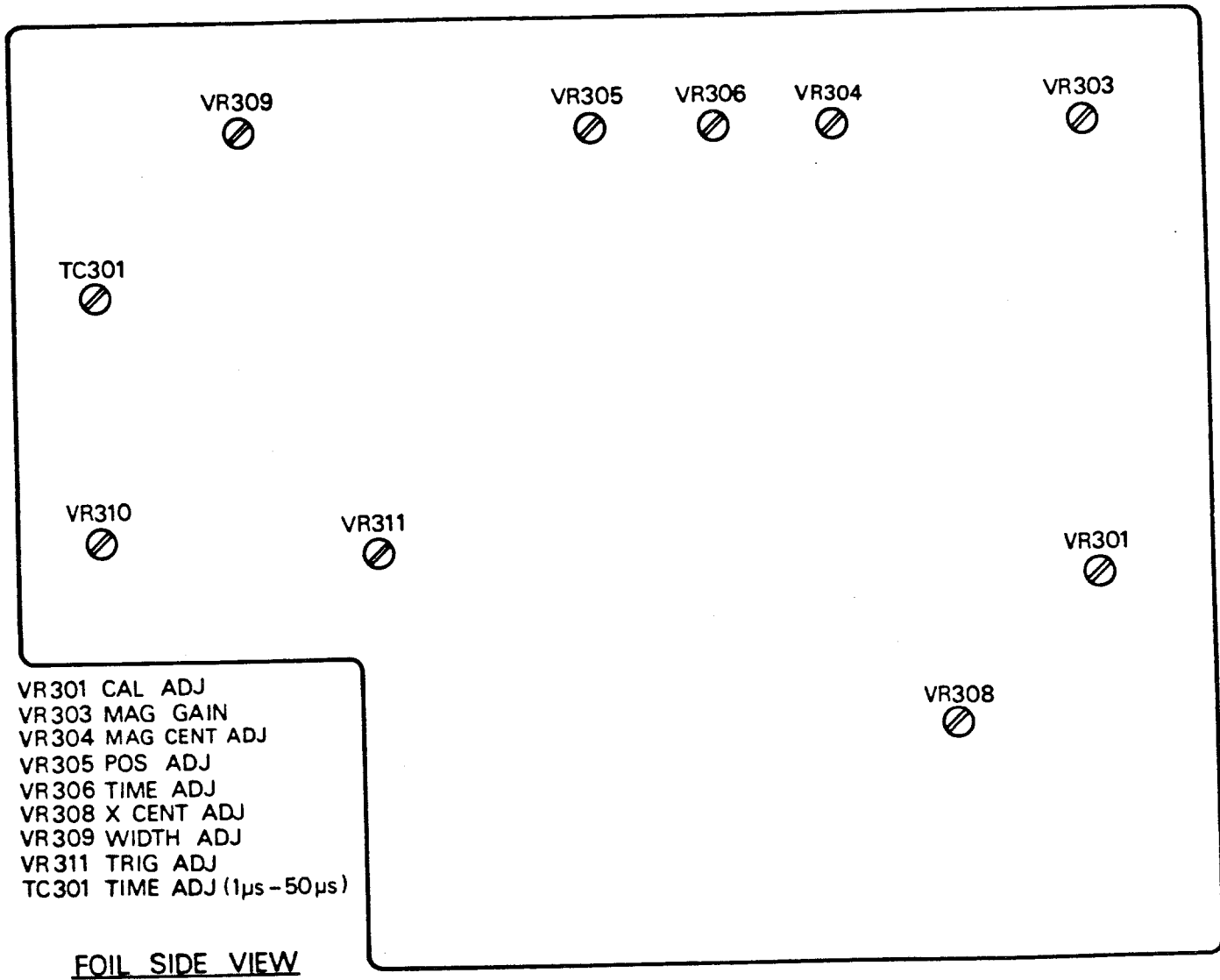

Fig. 11. Calibration diagram, horizontal amplifier board.
 Model 1476

CALIBRATION

The following points have been already adjusted. However, observe the following notes before making readjustment:

1. Calibrating the power source voltage.
2. For adjustment, use a well-insulated flat-blade screw-driver.
3. For optimum adjustment, turn the power on and warm up the oscilloscope sufficiently before starting.
4. All adjustment should follow the following order.
If this order reversed or only a partial adjustment is attempted, this may influence on the other part of the circuit.
5. Accurate measuring instruments should be employed.
6. Before making adjustment, set the operating controls unless otherwise specified a follows.

Name of knob	Position
SWEEP TIME/DIV	1 ms
SWEEP VARIABLE	CAL
◀▶H. POSITION VR	Mechanical center
◀▶H. POSITION × 5 MAG	PUSH
INTENSITY	3 o'clock position
TRIG LEVEL VR	Mechanical center
TRIG LEVEL AUTO	PULL
SYNC	SLOPE
SOURCE	INT
FOCUS	Optimum position
CH1 V. POSITION	Mechanical center
CH1 AC-GND-DC	AC
CH1 VOLTS/DIV	10mV
CH1 V. VARIABLE	CAL
CH2 V. POSITION	Mechanical center
CH2 AC-GND-DC	AC
CH2 VOLTS/DIV	10mV
CH2 V. VARIABLE	CAL

POWER AND CRT CIRCUIT ADJUSTMENTS

- 1.9 kV Adjustment

1. Connect a DC voltmeter to measure the voltage at the CRT's socket pin 1 or 3 with respect to chassis.
2. Adjust VR107 for a - 1.9 kV reading on the meter.

+ 180 V Adjustment

1. Connect a DC voltmeter to measure the voltage at the pin 15 of P118 with respect to chassis.
2. Adjust VR109 for + 180 V reading on the meter.

INTENSITY Adjustment

1. Pull the PULL AUTO knob to display a horizontal trace.
2. Adjust VR108 so that the trace disappears when the INTENSITY control setting is reduced to the 10-o'clock position.

ASTIG Adjustment

1. Set the SWEEP TIME/DIV control to X-Y position and both CH1 and CH2 AC-GND-DC switches to GND position.
This will produce a spot on the screen.
2. Adjust the FOCUS and ASTIG controls on the front panel for the sharpest, roundest spot. If the spot does not round and sharp, adjust VR106 for the sharpest, roundest spot.

Do not readjust the ASTIG control after this step.

VERTICAL AXIS ADJUSTMENT

DC BAL adjustments

VARI ATT BAL and STEP ATT BAL Adjustments

1. Set scope controls for a single horizontal trace on CH1 with the CH1 AC-GND-DC switch set to GND position and set the SWEEP TIME/DIV control to 1 ms position.
2. Rotate the CH1 VARIABLE control from maximum clockwise to maximum counterclockwise, while observing the trace.
3. If the trace moves vertically, adjust VR101 for minimum or zero vertical movement when performing step 2.
4. Rotate the CH1 VOLTS/DIV CONTROL through the 1 mV, 50 mV and 20 V position while observing the trace.
5. If the trace moves vertically, adjust VR401 for minimum or zero vertical movement when performing step 4.
6. Repeat the entire procedure for CH2, adjusting VR111 for VARIABLE balance and VR402 (VOLTS/DIV) STEP balance.

NOTE:

After adjusting VARI, be sure adjust STEP.

◆ POSITION and CRT Centering Adjustment

1. Set the CH1 AC-GND-AC switch to the GND position, the MODE switch to the DUAL position and SWEEP TIME/DIV control to 1 ms position.
2. Set the CH1 and CH2 ◆ POSITION controls to these mechanical center.
3. Pull the PULL AUTO knob to display a trace.
4. Short-circuit the test terminal TP101 and TP102 of the vertical amplifier board.
5. Adjust VR105 to center the trace vertically.

CALIBRATION

Vertical Gain Adjustment

1. Set the MODE switch to the CH1 position.
2. Connect the CH1 input terminal to the CAL Vp-p terminal.
3. Set the CH1 VARIABLE control to the CAL position, and the VOLTS/DIV control to 20 mV (probe set for DIRECT measurement).
4. Adjust VR103 for exactly 5 divisions vertical amplitude of 1 kHz square wave signal display.
5. Repeat the entire procedure for CH2, adjusting VR113.

1 kHz Square Wave Compensation

1. Set the VOLTS/DIV control to 1 mV and apply a 1 kHz, 50 mV square wave signal.
2. Rotate the VOLTS/DIV control to 10 mV (10:1), 1 V (100:1) and 10 V (1000:1) position.
3. Adjust TC101 (10:1), TC102 (100:1) and TC103 (1000:1) to make sure that the vertical amplitude is set to 5 divisions on the screen.
4. Repeat the entire procedure for CH2, adjusting TC104 (10:1), TC105 (100:1) and TC106 (1000:1).

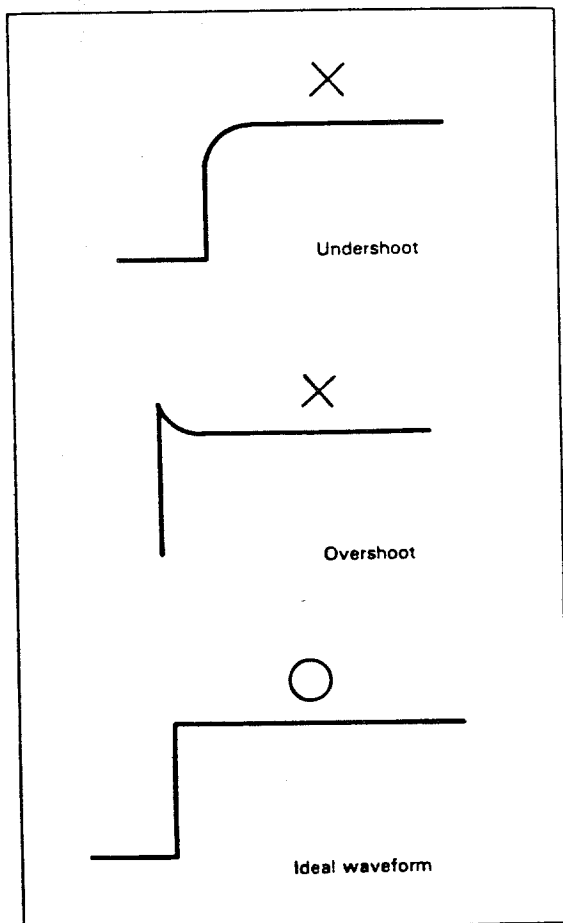

Fig. 12. 1 kHz Square wave compensation

100 kHz Square Wave Compensation

1. Set the VOLTS/DIV control 1 mV, the MODE switch to CH1 position.
2. Apply a 100 kHz square wave signal through a 50 Ω terminator to the CH1 input and adjust the vertical amplitude to 5 divisions on the screen.
3. Rotate the VOLTS/DIV control to 10 mV, 1 V and 10 V position.
4. Adjust TC113 and VR104 to make sure that the vertical amplitude is set to 5 divisions on the screen.

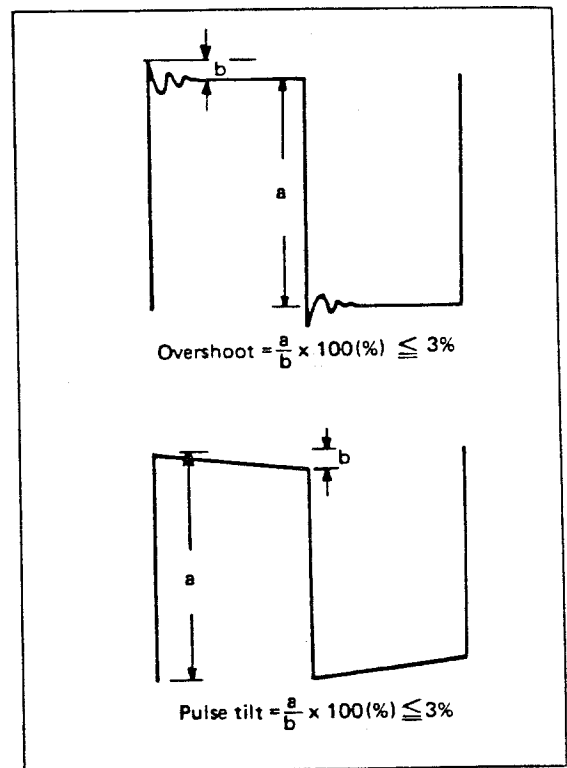

Fig. 13. 100kHz Squarewave Compensation

Input Capacitance

The object of this procedure is to equalize the input capacitance of the oscilloscope for all ranges of the vertical attenuators. This is accomplished by first using the 22 pF capacitance of the 10 mV range as the tuning capacitor for a test oscillator, thus establishing a reference frequency. The reference frequency is measured on a frequency counter. The specific frequency at which the test oscillator operates is not critical, but the frequency should be stable at approximately 5 MHz. The attenuator is then switched to other ranges. The input capacitance of the oscilloscope equals that of the 10 mV range when the trimmer associated with each set of ranges is adjusted so the test oscillator again operates at the reference frequency. Use a non-metallic tool for adjusting trimmers.

CALIBRATION

1. Turn on the oscilloscope during this procedure.
2. Fabricate the test oscillator shown in Fig. 14. Connect the output of the test oscillator to a frequency counter. Connect the CH A INPUT jack of the oscilloscope as the tuning capacitor of the test oscillator.
3. Set the CH A VOLTS/CM attenuator to the 10 mV range.
4. Measure and record the reference frequency of the test oscillator on the frequency counter.
5. Rotate the VOLTS/DIV control through 10 mV, 1 V and 10 V position, adjusting TC107 (10:1), TC108 (100:1) and TC109 (1000:1) for the same reference frequency obtained in step 4.
6. Repeat the entire procedure for CH2, adjusting TC110, TC111 and TC112.

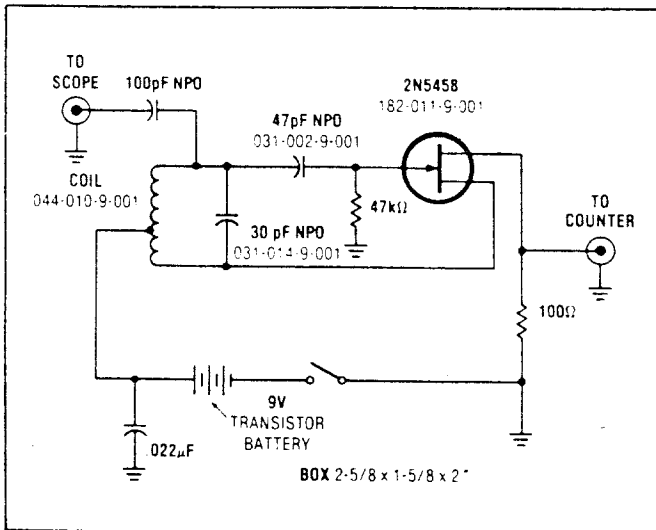

Fig. 14. Test oscillator for input capacitance calibration.

CALIBRATING VOLTAGE ADJUSTMENT

1. Connect output of CAL \square 1 Vp-p terminal to CH1 input and set oscilloscope controls to display one cycle of square wave.
2. The CH1 attenuator must be previously calibrated as prescribed in this manual to perform this step. Set CH1 VOLTS/DIV control to 0.2 V position and VARIABLE control to CAL, adjust VR301 for 5 divisions amplitude.

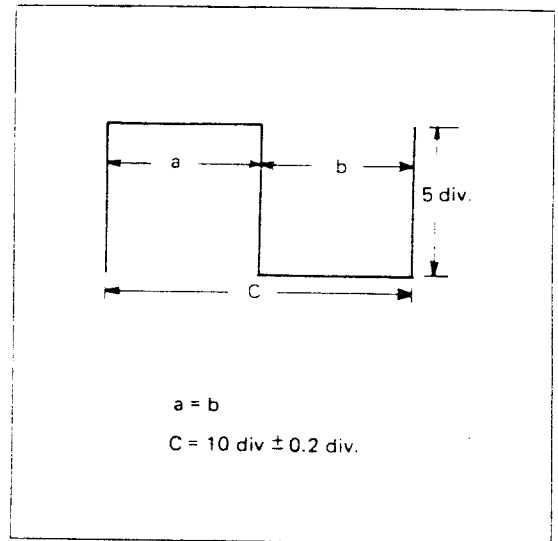

Fig. 15

HORIZONTAL SWEEP AXIS ADJUSTMENT

Sweep Time and Length Adjustments.

1. Set SWEEP TIME/DIV control to 0.1 ms position and VARIABLE control to CAL.
2. Apply 1 ms marker signal to CH1 input terminal.
1. Adjust VR306 so that the 10 visible marker occupy exactly 9 divisions of horizontal deflection as shown in Fig.

16.

3. Adjust VR309 for a total sweep length of 10-1/2 divisions.

◄► POSITION Adjustment

1. Set ◄► POSITION control at its mechanical center.
2. Set oscilloscope controls to display a single horizontal trace.
3. With the SWEEP TIME/DIV control, set to 0.1 ms, apply 1 ms marker signal to the CH1 to display 3 wave on the screen as shown in Fig. 17.

4. Next, adjust VR305 until the center of the 3 waves corresponds to the Y-axis on the graticule scale.

10 μs Range Adjustment

1. Set the SWEEP TIME/DIV control to 10 μs and apply 10 μs marker signal to the CH1 input terminal.
2. Adjust TC301 to duplicate the conditions shown in Fig.

16.

MAG Centering and MAG Gain Adjustment Fig. 18.

1. With the SWEEP TIME/DIV control to 0.1 ms, apply a 1 ms marker signal to the CH1 input terminal to display 11 pulses on the screen.
2. Alternately pull and push the x5 MAG knob. Adjust VR304 (MAG centering) so that the center marker remain stationary whether the PULL x MAG switch is on or off. Do not rotate the ◄► POSITION control.
3. Adjust VR303 (MAG gain) so that the marker is one division apart in normal operation are exactly 5 divisions apart in x5 MAG operation.

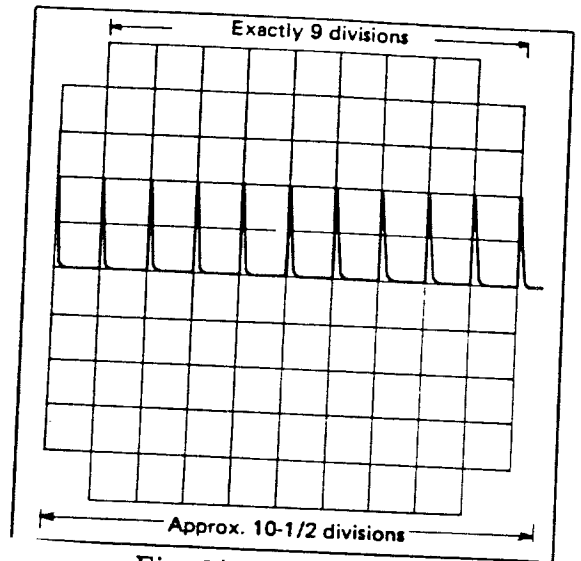

Fig. 16. Sweep Length

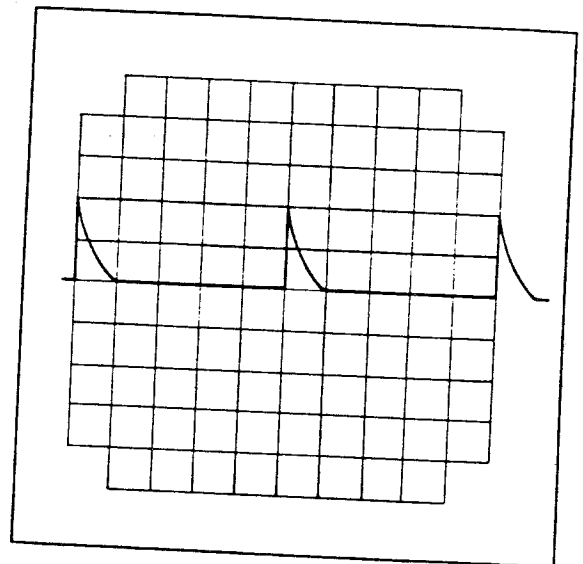

Fig. 17.

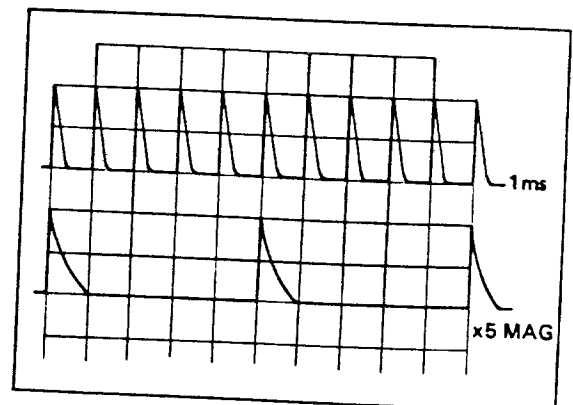

Fig. 18.

CALIBRATION

X POSITION and Gain Adjustment

1. Set the CH2 \blacklozenge POSITION control to its mechanical center.
2. Set the CH2 AC-GND-DC switch to GND position.
3. Set the SWEEP TIME/DIV control to X-Y position. A spot should appear on the screen.
4. Adjust the VR308 (X position) to center the spot horizontally on the screen.
5. Set the CH2 VOLTS/DIV control to 0.1 mV position and VARIABLE knob to CAL.
6. Set the CH2 AC-GND-DC switch to AC position and apply a calibrated 1 kHz, 50 mVp-p sine wave to the CH2 input terminal.
7. Adjust VR110 (X gain) for exactly 5 divisions horizontal deflection on the screen.

Triggering Level Adjustment **Fig. 19.**

1. Apply a 1 kHz sine wave and set the oscilloscope controls to display waveform on the screen at 5 divisions amplitude.
2. Adjust VR311 to make waveform stable with TRIG LEVEL control at its mechanical center.
3. Triggering should be satisfactory when amplitude is less than 1 division through a frequency range of 20 Hz to 10 MHz.

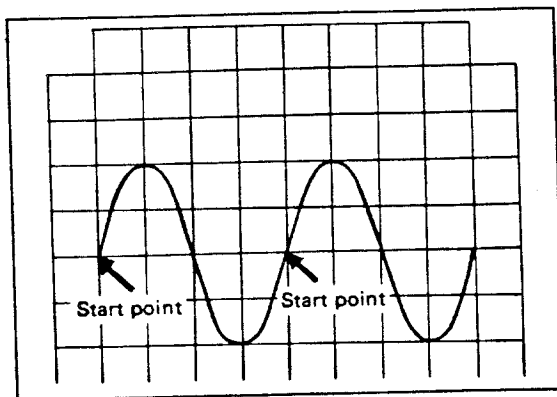
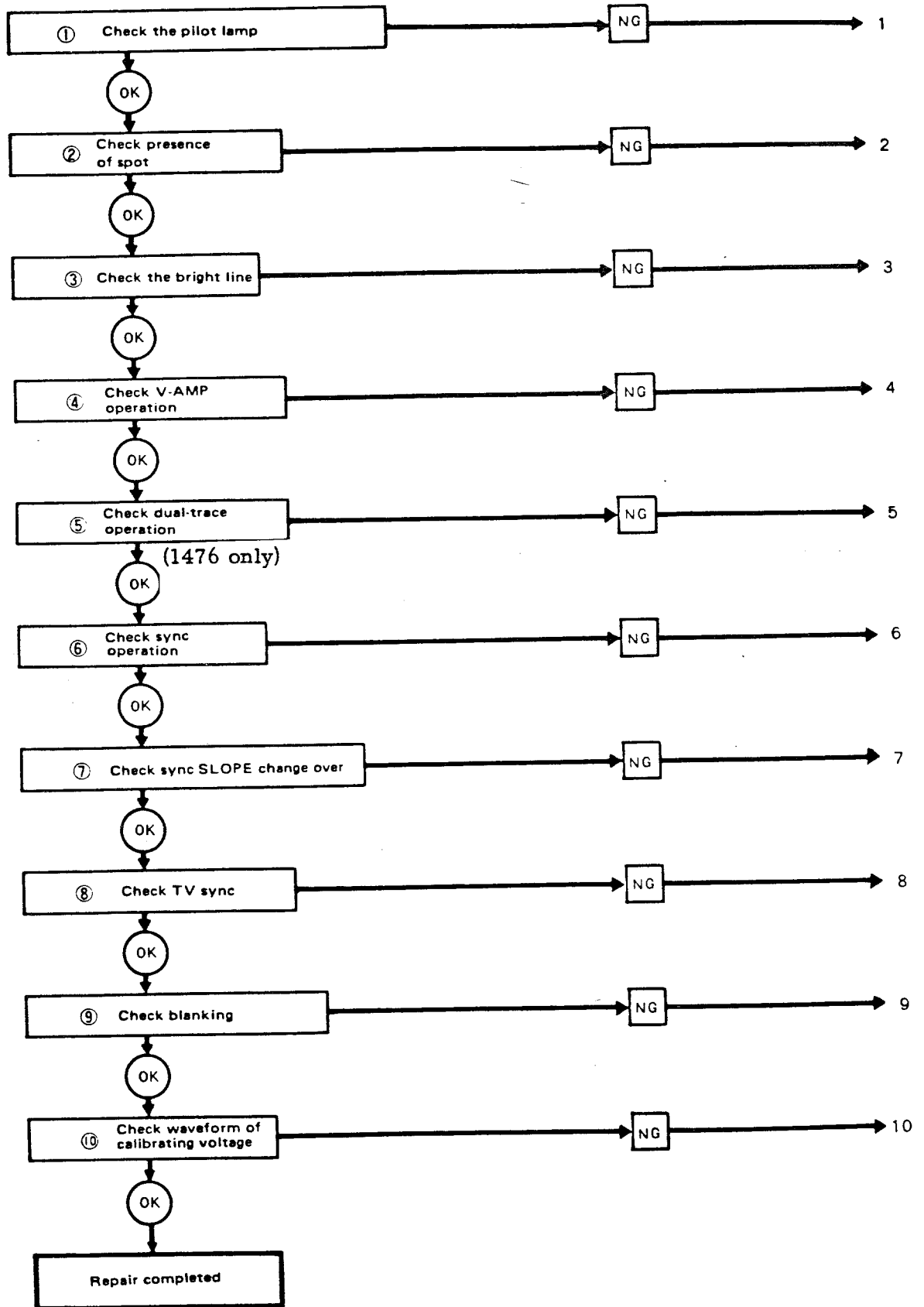

Fig. 19.

TROUBLESHOOTING

TROUBLESHOOTING



TROUBLESHOOTING

Models 1466 and 1476

Notes:

1. Parts without particular notes belong to the main body.
2. X65 ... denotes X65-1140-22.
3. X74 ... denotes X74-1060-00.

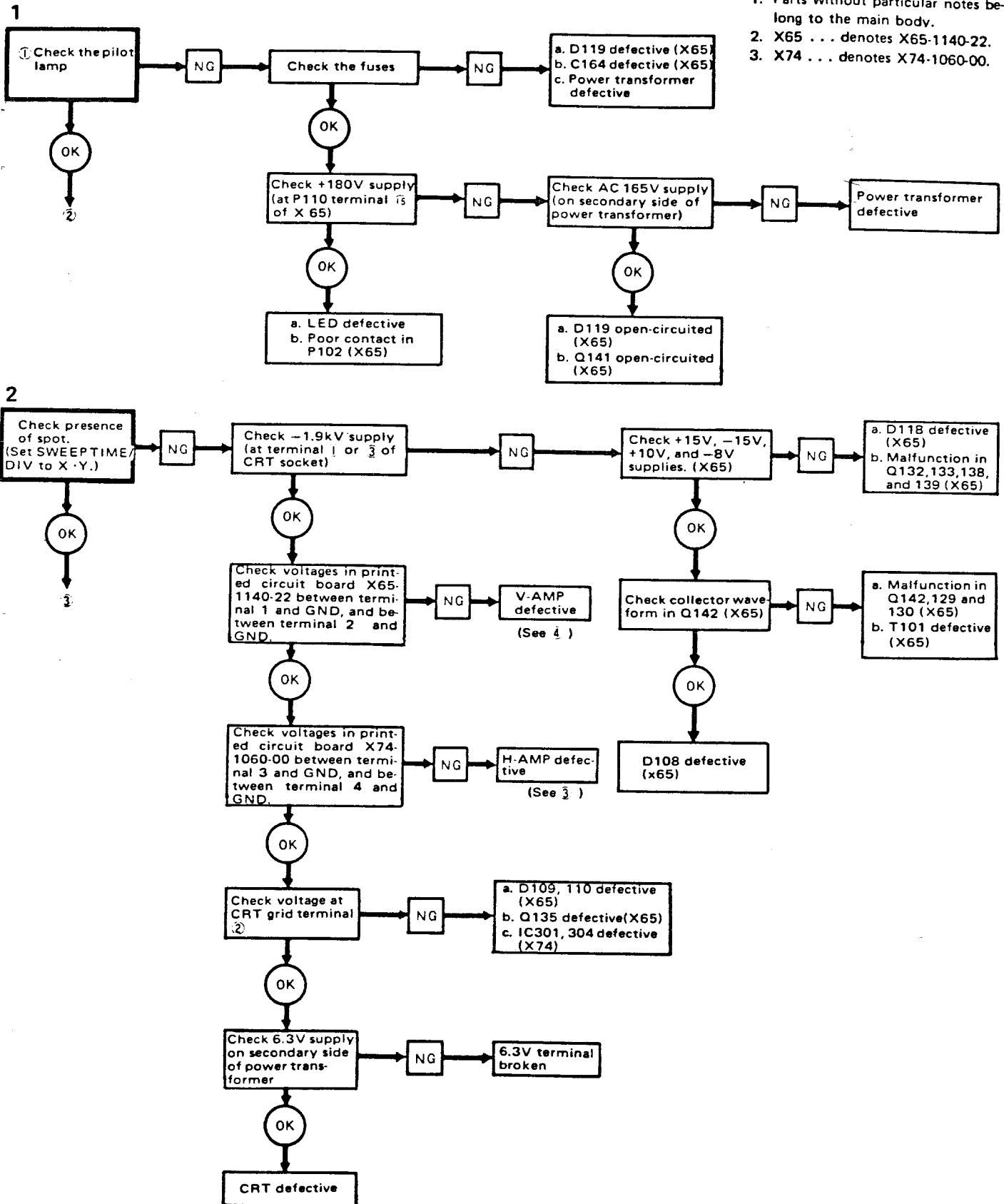

TROUBLESHOOTING

(1476 only)

3

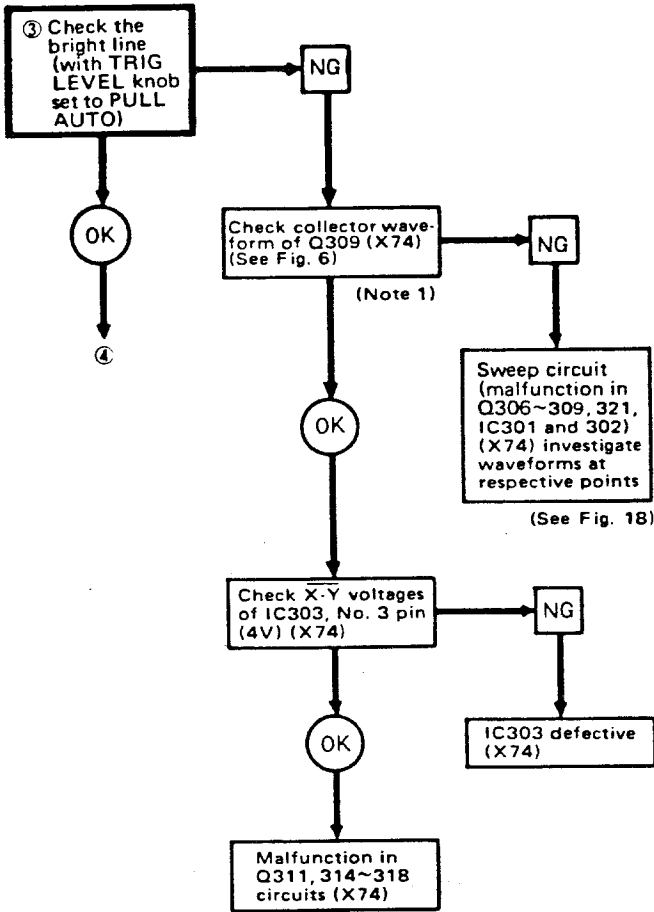

Note 1:
Add sine wave of 2 kHz to CH1 or CH2 vertical input terminal.

Fig.18 Waveform in SWEEP Circuit
(Input Signal 2 kHz, Sine Wave)
(SWEEP TIME 0.1 mS/DIV)
(X74-1060-00)

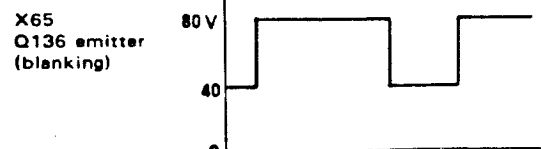
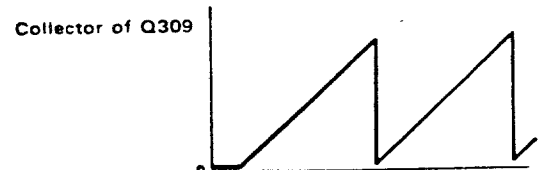
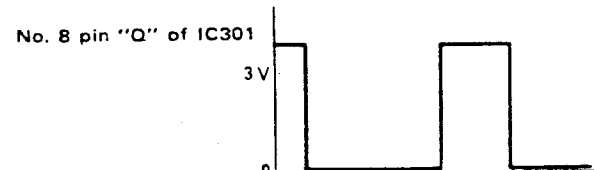
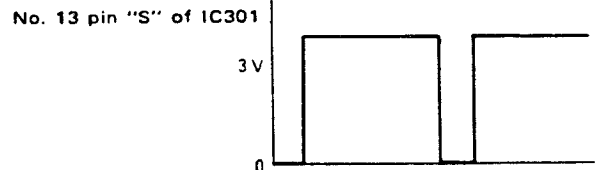
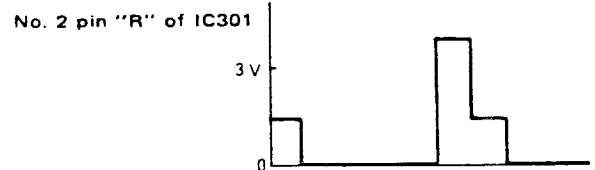
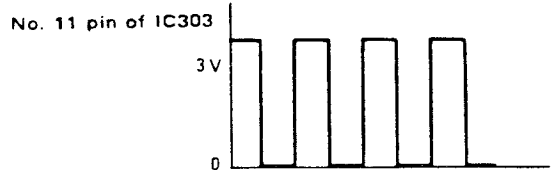
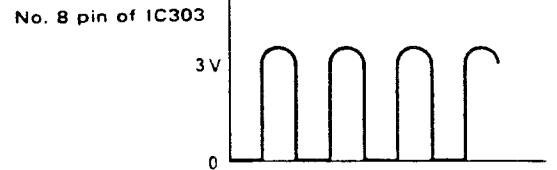
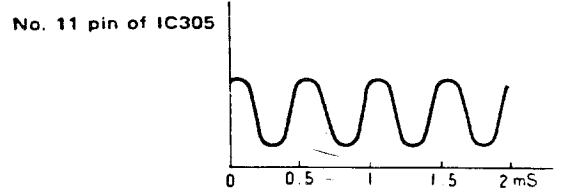

TROUBLESHOOTING

(1476 only)

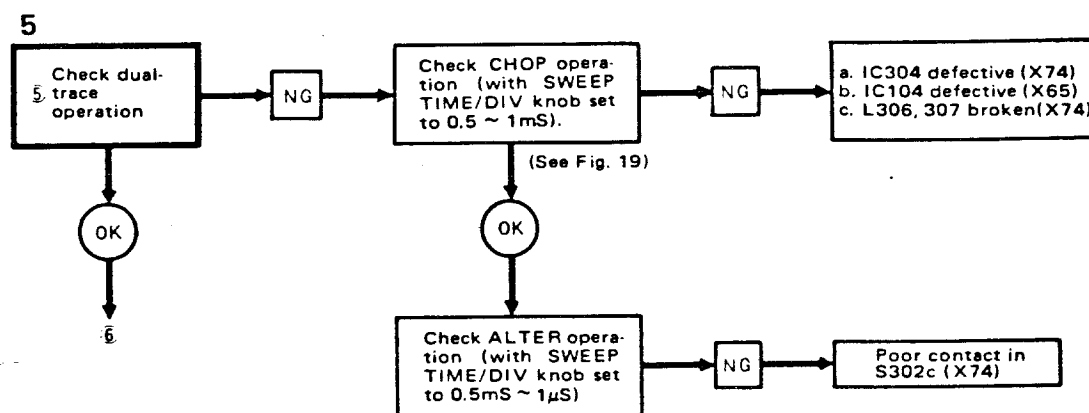
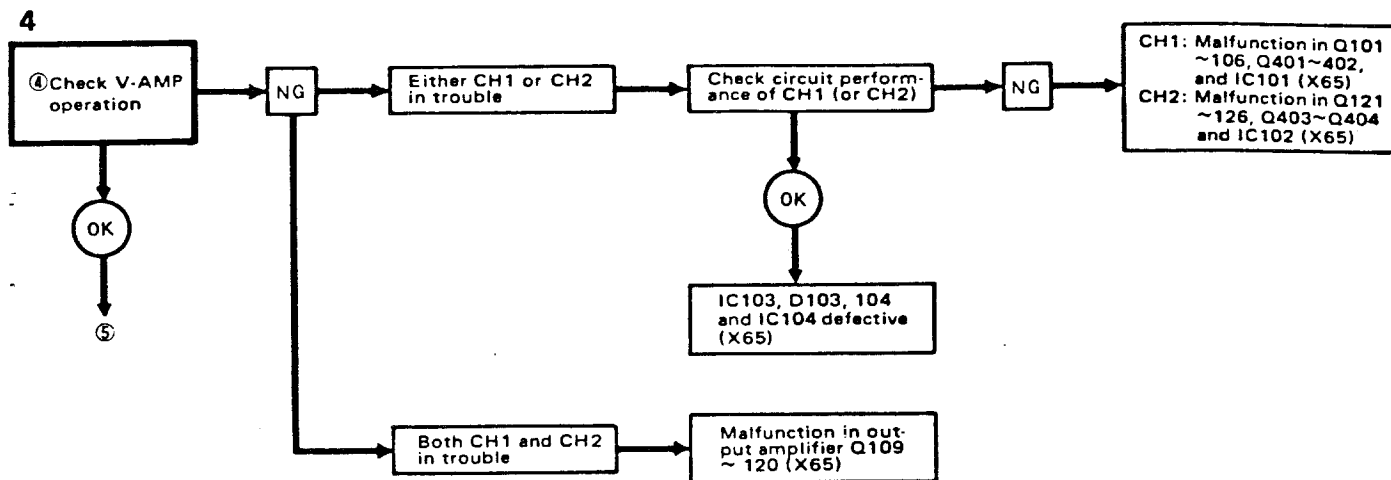

Note:

Add sine wave of 2 kHz to CH1 or CH2 vertical input terminal when checking items No. 4 ~ 9 (except No. 8).

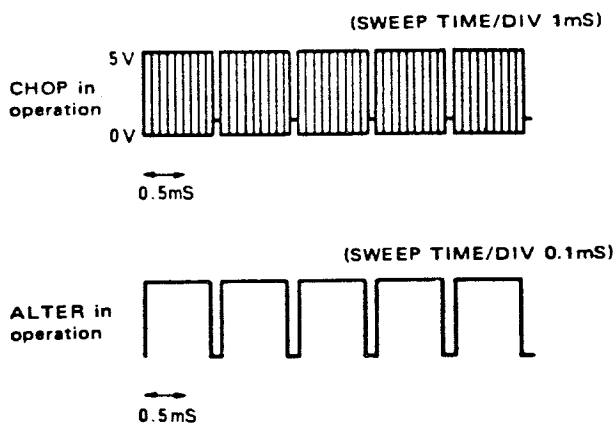
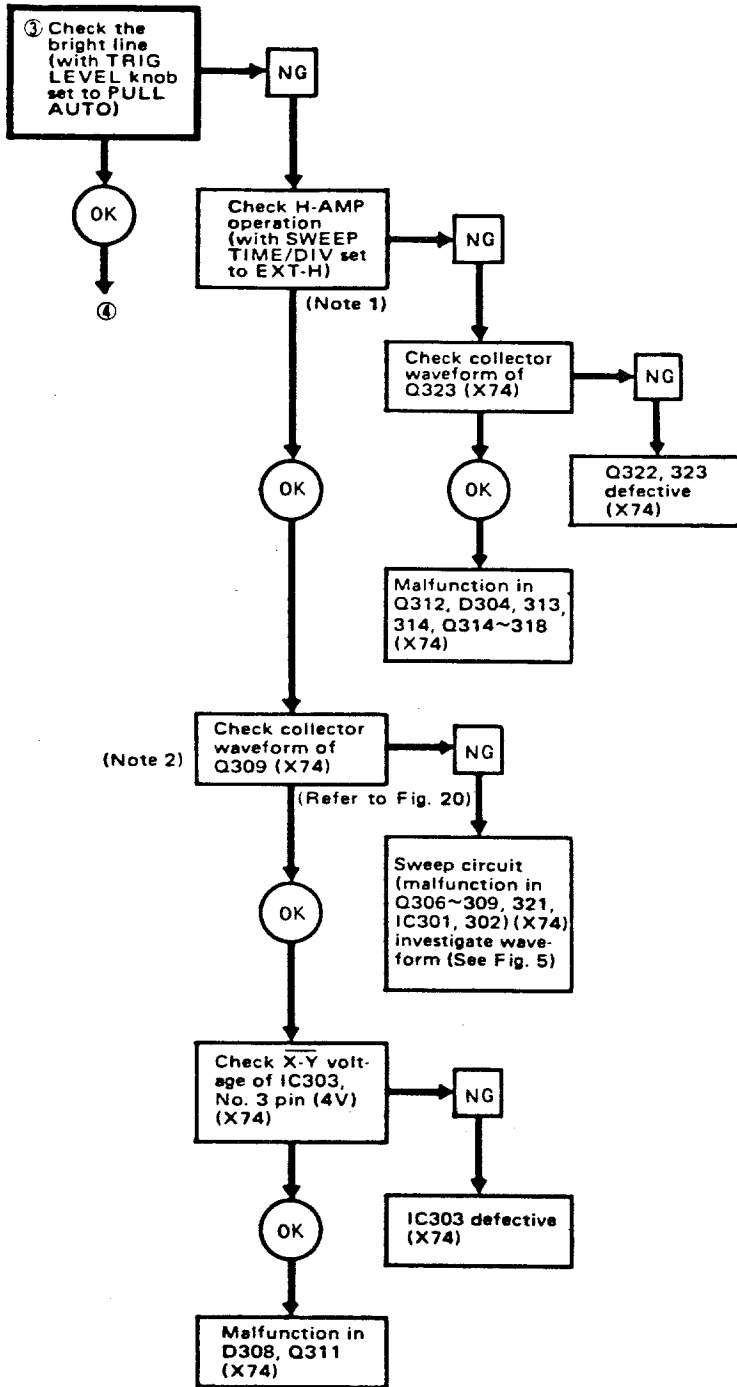

Fig. 19 C, P Waveforms at No. 8 Pin of J310

TROUBLESHOOTING

(1466 only)

3



Notes:

1. Add sine wave of 1 kHz, 2V to HOR, INPUT terminal.
2. Add sine wave of 2 kHz to vertical input terminal.

Fig. 20 Waveform in SWEEP Circuit
(Input Signal 2 kHz, Sine Wave)
(SWEEP TIME 0.1 mS/DIV)
(X74-1060-01)

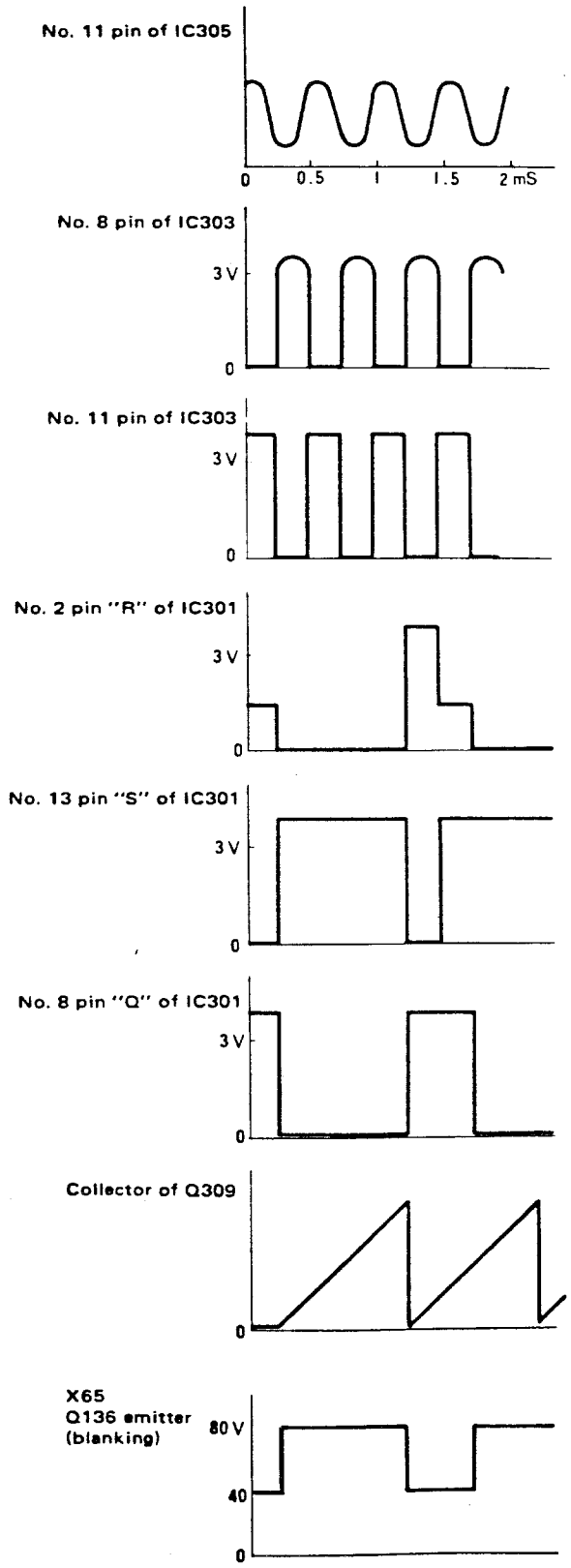

TROUBLESHOOTING

(1466 only)

Note: Add sine wave of 2 kHz to vertical input terminal when checking items No. 4~8 (except No. 7).

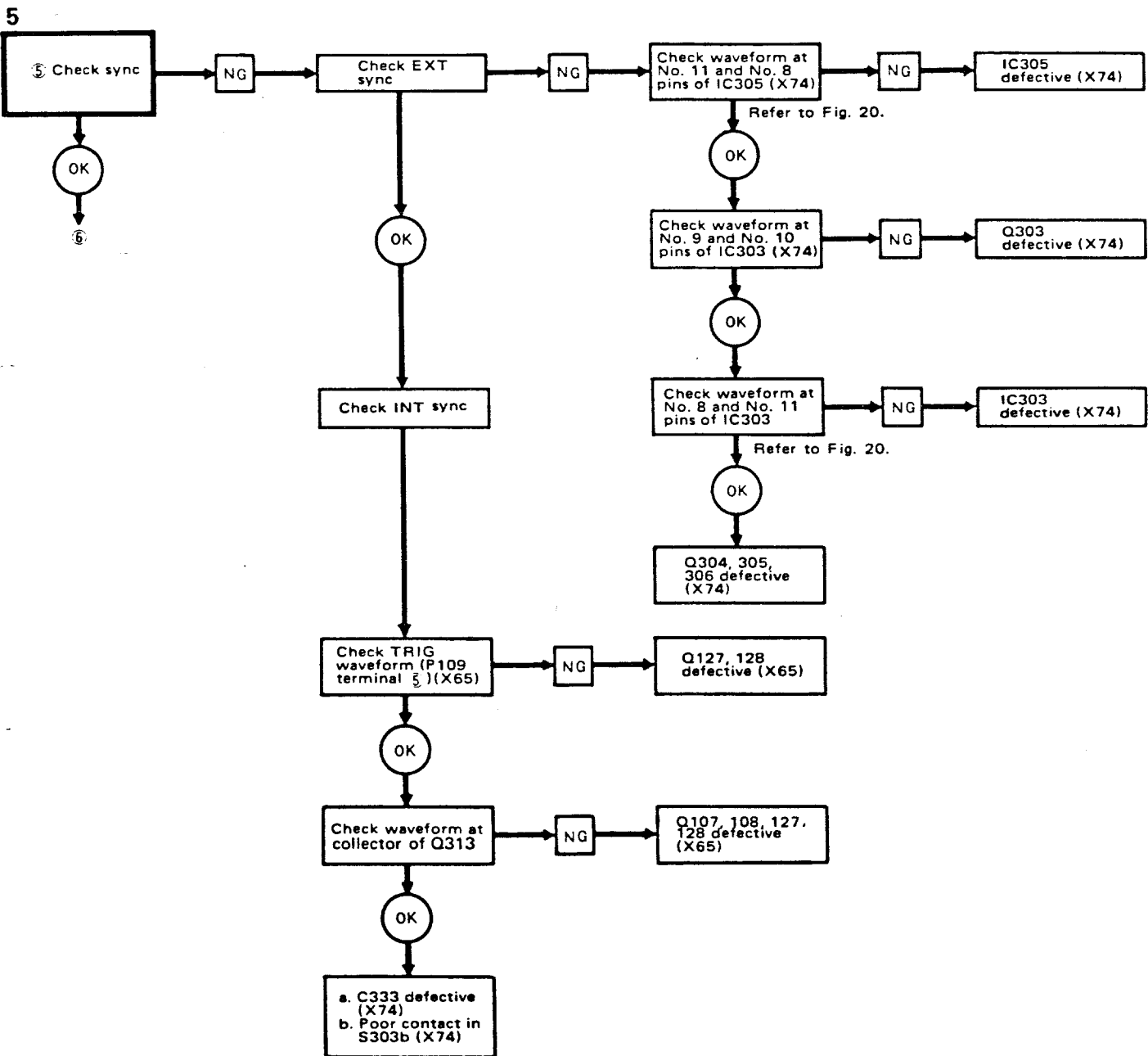
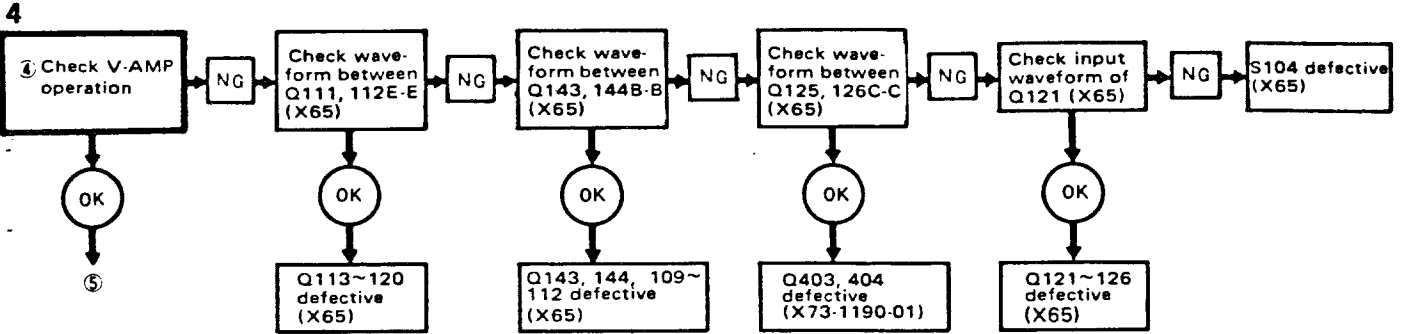

TROUBLESHOOTING

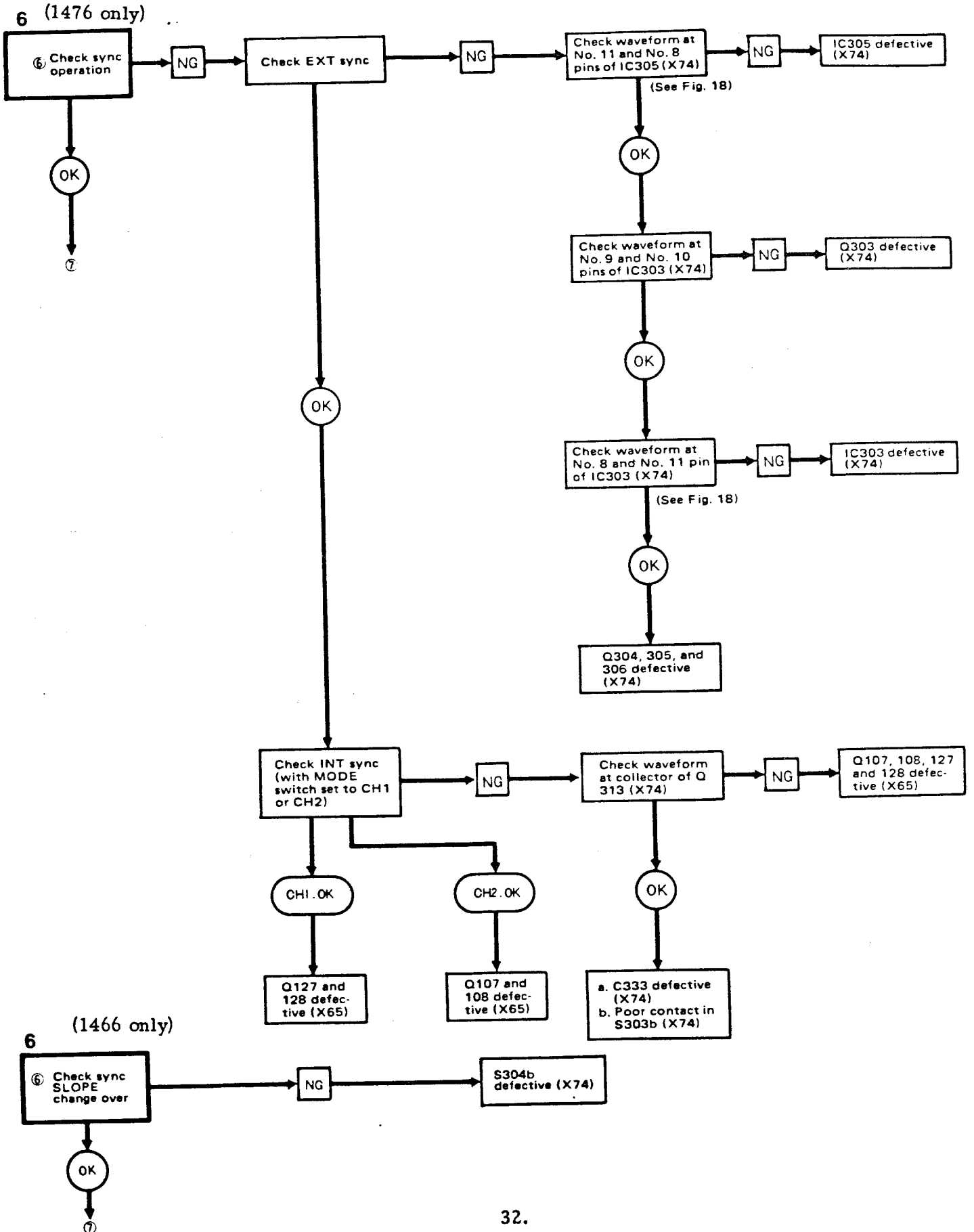

TROUBLESHOOTING

Models 1466 and 1476

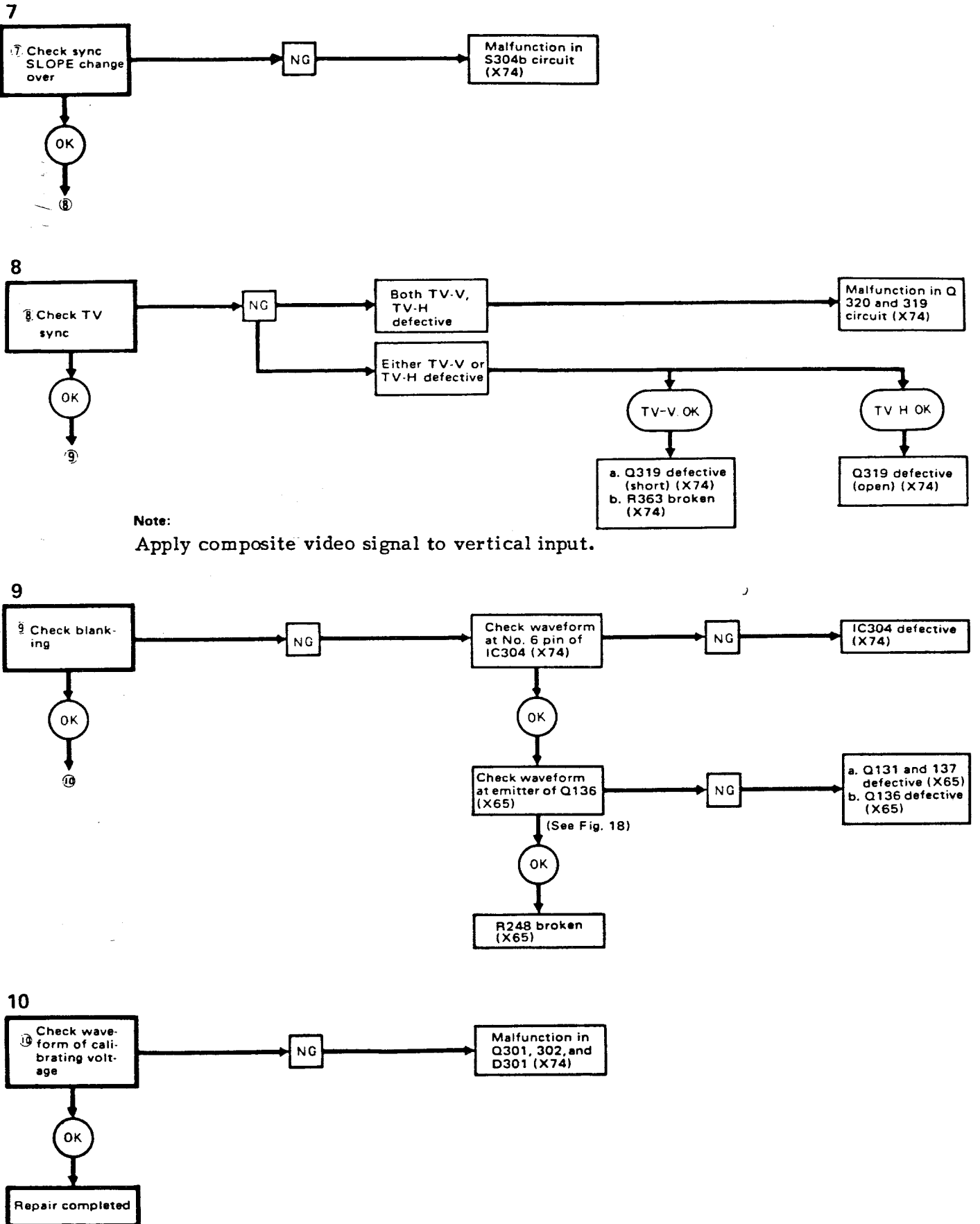

B & K-PRECISION MODEL 1466 PARTS LIST

10 MHz Single Trace
OSCILLOSCOPE

SCHEMATIC
SYMBOL

Parts List
488-240-9-002

B & K-PRECISION
PART No.

DESCRIPTION
VERTICAL AMPLIFIER, POWER SUPPLY UNIT

RESISTORS & CONTROLS

R152	900K Ω , 1/4W, $\pm 1\%$ Metal-Coated	013-010-9-011
R153	990K Ω , 1/4W, $\pm 1\%$ Metal-Coated	013-010-9-012
R154	999K Ω , 1/4W, $\pm 1\%$ Metal-Coated	013-010-9-013
R155	111K Ω , 1/4W, $\pm 1\%$ Metal-Coated	013-010-9-010
R156	10.1K Ω , 1/4W, $\pm 1\%$ Metal-Coated	013-010-9-008
R157	1K Ω , 1/4W, $\pm 1\%$ Metal-Coated	013-010-9-004
R158	1M Ω , 1/2W, $\pm 1\%$ Metal-Coated	013-008-9-023
R169, 170, 262	8.2K Ω , 1/4W, $\pm 1\%$ Metal-Coated	013-010-9-007
R171, 172, 261	4.3K Ω , 1/4W, $\pm 1\%$ Metal-Coated	013-010-9-005
R173, 174	560 Ω , Metal-Coated	004-164-9-001
R175	741 Ω , 1/4W, $\pm 1\%$ Metal-Coated	013-020-9-001
R176	392 Ω , 1/4W, $\pm 1\%$ Metal-Coated	013-020-9-002
R177	115 Ω , 1/4W, $\pm 1\%$ Metal-Coated	013-020-9-003
R180, 181	3K Metal-Coated	013-028-9-001
R270	300K Ω , 1/4W, $\pm 1\%$ Metal-Coated	013-008-9-021
R278	13.3K Ω , 1/4W, $\pm 1\%$ Metal-Coated	013-010-9-009
VR1	Potentiometer, 3M Ω , "FOCUS"	008-235-9-001
VR2, S1	Potentiometer, 1K Ω , "INTENSITY"	008-235-9-004
VR111	Potentiometer, 470 Ω	008-235-9-002
VR112	Trimpot, 500 Ω	008-317-9-001
VR113	Potentiometer, 150 Ω	008-233-9-001
VR104	Potentiometer, 1K Ω	008-155-9-005
VR105, 107, 108	Potentiometer, 47K Ω	008-169-9-008
VR106	Potentiometer, 330K Ω , "ASTIGMATISM"	008-163-9-010
VR109	Potentiometer, 2.2K Ω	008-233-9-002
VR115	Trimpot, 5K Ω	008-282-9-002

CAPACITORS

C112, 160	47 μ F, 16V Electrolytic	022-090-9-003
C114, 157, 163	33 μ F, 25V Electrolytic	022-135-9-001
C121	.1 μ F Metal Film	033-019-9-002
C129, 132, 158, 159	100 μ F, 10V Electrolytic	022-123-9-002
C141	1000pF, 2KV Ceramic	020-163-9-005
C142, 143, 144, 145	.01 μ F, 2KV Disc Ceramic	020-124-9-011
C148	470 μ F, 50V Electrolytic	022-135-9-003
C156	1 μ F, 250V Electrolytic	021-059-9-001
C162, 165	1000 μ F, 25V Electrolytic	022-135-9-002
C164	47 μ F, 250V Electrolytic	021-057-9-001
TC104, 105, 106	6pF, Trimmer	028-033-9-001
TC110, 111, 112, 113	10pF, Trimmer	028-033-9-002

SEMICONDUCTORS & IC'S

IC105	IC Linear, RC4558T	307-069-9-005
Q109, 110, 111, 112, 119, 120, 123, 124, 130, 132, 133	NPN Silicon Signal, 2SC945-P	176-055-9-002

B & K-PRECISION MODEL 1466 PARTS LIST

SCHEMATIC SYMBOL	DESCRIPTION	B & K PART NO.
---------------------	-------------	-------------------

SEMICONDUCTORS & IC'S, cont'd.

Q113, 114, 125, 126, 131, 143, 144, 145 }	NPN Silicon Signal, 2SC535-C	176-055-9-001
Q115, 116	NPN Silicon Signal, 2SC1628-Y	176-055-9-005
Q117, 118	PNP Silicon Signal, 2SA818-Y	177-018-9-003
Q121	Dual FET, 2SK58-1-M	182-050-9-001
Q122	FET Transistor, 2SK30A-O	182-026-9-001
Q127, 128, 129	PNP Silicon Signal, 2SA733-Q	177-018-9-001
Q134, 135, 136, 137	NPN Silicon Signal, 2SC983-Y	176-053-9-002
Q138	NPN Silicon Signal, 2SC1213A(C)	176-055-9-003
Q139	NPN Silicon Signal, 2SC1419-C	176-055-9-004
Q140	PNP Silicon Signal, 2SA755-C	177-018-9-002
Q141	PNP Silicon Signal, 2SB536(2)LM	173-004-9-001
Q142	NPN Silicon Signal, 2SD401	172-037-9-001
D105, 106, 114, 115 121	Diode Silicon, 1S1555	151-028-9-007
D107, 116	Zener Diode, WZ100	152-050-9-003
D108	Diode, High-Voltage Silicon, Y16JA	151-048-9-003
D109, 110, 111	Diode Silicon, WO6C	151-052-9-002
D112	Diode, Silicon, 1S1705	151-052-9-001
D113	Zener Diode, WZ050	152-069-9-001
D117	Zener Diode, WZ090	152-069-9-002
D118, 119	Bridge Rectifier, S1QB60	157-006-9-001

SWITCHES & CONTROLS

S103	Lever Switch, "AC/GND/DC"	080-003-9-001
S104	Rotary Switch, "VOLTS/CM"	083-204-9-001

COILS & TRANSFORMERS

T101	Converter Transformer	064-015-9-001
L101, 102	Fixed Inductor, 47 μ H, \pm 10%	041-068-9-002
L103, 104	Fixed Inductor, 68 μ H, \pm 10%	041-068-9-009
L107	Fixed Inductor, 470 μ H, \pm 10%	041-071-9-001
L108	Fixed Inductor, 4.7 μ H, \pm 10%	041-068-9-008

HORIZONTAL AMP/SWEEP P.C. BOARD

RESISTORS & CONTROLS

R324	3M Ω , 1/4W, \pm 1% Carbon	013-010-9-015
R325, 379	100K Ω , 1/4W, \pm 1% Metal-Coated	013-008-9-020
R326	300K Ω , 1/4W, \pm 1% Metal-Coated	013-008-9-021
R327	500K Ω , 1/4W, \pm 1% Metal-Coated	013-008-9-022
R328	1M Ω , 1/4W, \pm 1% Metal-Coated	013-008-9-023
R345, 346	15K Ω , 2W, \pm 2% Metal-Coated	013-010-9-016
R347	680 Ω , 1/4W, \pm 1% Metal-Coated	013-010-9-018
R378	68K Ω , 2W, \pm 5% Metal-Coated	013-010-9-017
VR3, VR3-2	Potentiometer, 5K "POSITION"	008-282-9-001
VR301, 304	Potentiometer, 470 Ω	008-163-9-008
VR303	Potentiometer, 150 Ω	008-174-9-002
VR305	Potentiometer, 10K Ω	008-155-9-004
VR306	Potentiometer, 22K Ω	008-163-9-010

B & K-PRECISION MODEL 1466 PARTS LIST

SCHEMATIC SYMBOL	DESCRIPTION	B & K PART NO.
RESISTORS & CONTROLS, cont'd.		
VR307, 312	Variable Resistor, 5K-100K Ω , "VARIABLE/HOR. GAIN"	008-282-9-003
VR309	Potentiometer, 4.7K Ω	008-155-9-002
VR310, S305	Variable Resistor, 50K Ω , W/Switch, "TRIG LEVEL"	008-226-9-003
VR311, 308	Potentiometer, 1K Ω	008-169-9-006
CAPACITORS & TRIMMERS		
C301, 302, 303, } 332, 333	1 μ F, 50V, Electrolytic	022-073-9-001
C306	.47 μ F, 1% Metalized Polystyrene	033-019-9-003
C307	.0047 μ F, 1% Metalized Polystyrene	033-019-9-004
C310	.22 μ F, 25WV Tantalum Condenser	027-011-9-001
C324	1500pF, \pm 10% 50V Polystyrene	030-037-9-001
C316, 317	.1 μ F Semiconductor Ceramic	033-018-9-001
C318, 319	220 μ F, 10V, Electrolytic	022-126-9-001
C322	220 μ F, 16V, Electrolytic	022-086-9-002
C323	.01 μ F, \pm 20%, 500V Disc Ceramic	020-111-9-005
C329	100 μ F, 10V Electrolytic	022-123-9-002
C330	47 μ F, 10V, Electrolytic	022-119-9-004
C331, 311	4700pF, 10%, 50V Polystyrene	030-036-9-007
C341	1 μ F, 250V, Electrolytic	021-059-9-001
TC301	Trimmer, 10pF	028-033-9-002
COILS		
L301, 302, 303	Ferri-inductor, 47 μ H	041-068-9-002
L304, 305	Ferri-inductor, 1mH	041-077-9-001
SEMICONDUCTOR & IC'S		
IC301	Digital IC, TD3472AP	307-069-9-003
IC302	Linear IC, RC555DN	307-094-9-001
IC303, 304	Digital IC, TD3400AP	307-069-9-004
IC305	Linear IC, AN606	307-071-9-003
Q301, 302, 303, 304, } 305, 306, 309, 310, } 311, 312, 313, 314, } 315, 316, 319, 320, } 321	NPN Silicon Signal, 2SC945P	176-055-9-002
Q307, 323	PNP Silicon Signal, 2SA733Q	177-018-9-001
Q308, 322	FET, 2SK30A-O	182-026-9-001
Q317, 318	NPN Silicon Signal, 2SC1507	176-055-9-006
D301, 302, 304, 305, } 306, 308, 309, 311, } 312, 313, 314, 315 }	Silicon Diode, 1S1555	151-028-9-007
D307	Silicon Diode, 1S1587	151-048-9-001
D316	Varistor STV-3H	005-003-9-001
TH301	Thermistor SDT-1000	005-003-9-002

B & K-PRECISION MODEL 1466 PARTS LIST

SCHEMATIC SYMBOL	DESCRIPTION	B & K PART NO.
SWITCHES		
S302 a, b, c	Rotary Switch, "SWEEP TIME/CM"	083-204-9-002
S303 a, b	Lever Switch, "SOURCE/INT-EXT"	080-004-9-001
S304 a, b,	Lever Switch, "SYNC"	080-004-9-002

VARIABLE AMP BOARD

C422, 425	47 μ F, 10V Electrolytic Capacitor	022-119-9-004
Q403, 404	Transistor, NPN Silicon, Signal 2SC535-C	176-055-9-001
R424, 426	182 Ω , 1/4W, \pm 1% Metal-Coated Resistor	013-020-9-005
VR402	100 Ω Potentiometer	008-282-9-004

MISCELLANEOUS

Case	272-148-9-001
Bezel, Assembly	380-340-9-001
Bezel	380-338-9-003
Bezel Frame	769-102-9-002
Graticule	482-164-9-002
CRT, C529P31B or 130BEB31	230-009-9-001
Filter, Screen	380-338-9-001
Fuse, 0.3A	191-010-9-001
Fuse, 0.7A	191-011-9-001
Knob, "VOLTS/CM", "SWEEP TIME/CM"	751-186-9-001
Knob, "VARIABLE," "VARIABLE/HOR GAIN"	751-186-9-003
Knob, "INTENSITY", "FOCUS", "TRIG LEVEL", etc.	751-186-9-002
Knob (Lever Switches)	751-186-9-004
Line Cord	420-013-9-001
Lamp Assembly	752-010-9-001
Power Transformer	065-124-9-001
Vector Overlay	482-044-9-001

NOTE: Standard value resistors and capacitors are not listed. Values may be obtained from schematic diagram. Minimum charge, \$5.00 per invoice. Orders will be shipped C.O.D. unless previous open-account arrangements have been made, or remittance accompanies your order. Advance remittance must include postage or other transportation charges. Please be sure to specify the serial number of your B & K-Precision test unit when ordering replacement parts for it.

BK-PRECISION DYNASCAN CORPORATION
6460 W. Cortland Street, Chicago, Illinois 60635

10 MHz Dual Trace OSCILLOSCOPE

SCHEMATIC SYMBOL	Parts List DESCRIPTION	488-241-9-002 B & K-PRECISION PART No.
---------------------	---------------------------	--

VERTICAL AMP AND POWER SUPPLY BOARD

RESISTORS & CONTROLS

R102, 152	900K Ω , 1/2W, $\pm 1\%$ Metal Coated	013-010-9-011
R103, 153	990K Ω , 1/2W, $\pm 1\%$ Metal Coated	013-010-9-012
R104, 154	999K Ω , 1/2W, $\pm 1\%$ Metal Coated	013-010-9-013
R105, 155	111K Ω , 1/2W, $\pm 1\%$ Metal Coated	013-010-9-010
R106, 156	10.1K Ω , 1/2W, $\pm 1\%$ Metal Coated	013-010-9-008
R107, 157	1K Ω , 1/2W, $\pm 1\%$ Metal Coated	013-010-9-004
R108, 158	1M Ω , 1/2W, $\pm 1\%$ Metal Coated	013-008-9-023
R119, 120, 169, } 170, 262 }	8.2K Ω , 1/2W, $\pm 1\%$ Metal Coated	013-010-9-007
R121, 122, 171, } 172, 261 }	4.3K Ω , 1/2W, $\pm 1\%$ Metal Coated	013-010-9-005
R123, 124, 173, } 174 }	560 Ω , Metal Coated	004-164-9-001
R125, 175	741 Ω , 1/2W, $\pm 1\%$ Metal Coated	013-010-9-003
R126, 176	392 Ω , 1/2W, $\pm 1\%$ Metal Coated	013-010-9-002
R127, 177	115 Ω , 1/2W, $\pm 1\%$ Metal Coated	013-010-9-001
R130, 131, 180, } 181 }	3.2k Ω , 1/2W, $\pm 1\%$ Metal Coated	004-164-9-002
R270	300K Ω , 1/2W, $\pm 1\%$ Metal Coated	013-008-9-021
R278	13.3K Ω , 1/2W, $\pm 1\%$ Metal Coated	013-010-9-009
VR101, 111	470 Ω Potentiometer	008-235-9-002
VR102, 112	500 Ω Variable Resistor, "POSITION"	008-235-9-003
VR103, 113	150 Ω Potentiometer	008-174-9-001
VR104	1K Ω Potentiometer	008-169-9-006
VR105, 107, 108	47K Ω Potentiometer	008-169-9-008
VR106	330K Ω Potentiometer	008-163-9-009
VR109	2.2K Ω Potentiometer	008-169-9-007
VR110	470 Ω Potentiometer	008-163-9-008
VR114, 115	5K Ω Variable	008-282-9-002

CAPACITORS & TRIMMERS

C101, 121	.1 μ F Metalized Polystyrene	033-019-9-002
C109, 129, 132, } 133, 158, 159 }	100 μ F, 10V Electrolytic	022-123-9-002
C112, 160	47 μ F, 16V Electrolytic	022-173-9-004
C114, 157, 163	33 μ F, 25V Electrolytic	022-135-9-001
C141	1000pF, 2KV Ceramic	020-163-9-005
C148	470 μ F, 50V Electrolytic	022-135-9-003
C156	1 μ F, 250V Electrolytic	021-041-9-001
C162, 165	1000 μ F, 25V Electrolytic	022-135-9-002
C164	47 μ F, 250V Electrolytic	021-057-9-001
TC101, 102, 103, } 104, 105, 106 }	6pF Ceramic Trimmer Capacitors	028-033-9-001
TC107, 108, 109, } 110, 111, 112, } 113 }	10pF Ceramic Trimmer Capacitors	028-033-9-002

B & K-PRECISION MODEL 1476 PARTS LIST

SCHEMATIC SYMBOL	DESCRIPTION	B & K PART NO.
RESISTORS & CONTROLS, Cont'd		
R378	68K Ω , 2W, \pm 5% Metal Coated	013-010-9-017
VR1	3M Ω , Potentiometer, "FOCUS"	008-235-9-001
VR2	1k Ω , Potentiometer, "INTENSITY"	008-292-9-001
VR3, S2	5k Ω , Potentiometer, "◀► POSITION", "MAG X5"	008-226-9-002
VR301, 304	470 Ω , Potentiometer	008-163-9-008
VR303	150 Ω , Potentiometer	008-174-9-002
VR305	10K Ω , Potentiometer	008-155-9-004
VR306	22K Ω , Potentiometer	008-163-9-010
VR307	5K Ω , Potentiometer	008-292-9-003
VR308, 309	4.7K Ω , Potentiometer	008-155-9-002
VR310, S305	50K Ω , Potentiometer w/switch, "TRIGGER LEVEL"	008-226-9-001
VR311	1K Ω , Potentiometer	008-155-9-005
CAPACITOR & TRIMMERS		
C301, 302, 303, } 332, 333	1 μ F, 50V, Electrolytic	022-086-9-004
C306	.47 μ F, 1% Metalized Polystyrene	033-019-9-003
C307	.0047 μ F, 1% Metalized Polystyrene	033-019-9-004
C310	.22 μ F, 25WV Tantalum Condenser	027-011-9-001
C313, 314, 324	1500pF, \pm 10%, 50V Polystyrene	030-037-9-001
C316, 317	.1 μ F Semiconductor Ceramic	033-018-9-001
C318, 319	220 μ F, 10V Electrolytic	022-126-9-001
C322	220 μ F, 16V Electrolytic	022-086-9-002
C323	.01 μ F, \pm 20%, 500V Disc Ceramic	020-111-9-005
C329	100 μ F, 10V Electrolytic	022-123-9-002
C330	47 μ F, 10V Electrolytic	022-119-9-004
C331, 311	4700pF, 10%, 50V Polystyrene	030-036-9-007
C341	1 μ F, 250V Electrolytic	021-059-9-001
SEMICONDUCTORS & IC'S		
D301, 302, 303, } 304, 305, 306, 308, 309, 310, 311	Diode, Silicon 1S1555	151-028-9-007
D307	Diode, Silicon 1S1587	151-048-9-001
Q301, 302, 303, } 304, 305, 306, 309, 310, 311, 312, 313, 314, 315, 316, 319, 320, 321	Transistor, NPN Silicon, Signal 2SC945P	176-055-9-002
Q307	Transistor, PNP Silicon, Signal 2SA733Q	177-018-9-003
Q308	Transistor, Field Effect 2SK30A-O	182-026-9-001
Q317, 318	Transistor, NPN Silicon 2SC1507	176-055-9-006
IC301	IC, Digital TD3472AP	307-069-9-003
IC302	IC, Linear RC555DN	307-094-9-001
IC303, 304	IC, Digital TD3400AP	307-069-9-004
IC305	IC, Linear AN606	307-071-9-003
INDUCTORS		
L301, 302, 303, } 306, 307	47 μ H Inductor Coil	041-068-9-002
L304, 305	1mH Inductor Coil	041-077-9-001
SWITCHES		
S302a, b, c	Rotary, "SWEEP TIME/CM"	083-004-9-001
S303a, b	Lever, "SOURCE"	080-004-9-001
S304a, b,	Lever, "SYNC"	080-004-9-002

B & K-PRECISION MODEL 1476 PARTS LIST

SCHEMATIC SYMBOL	DESCRIPTION	B & K PART NO.
VARIABLE AMP BOARD		
C402, 405, 422, 425 }	47 μ F, 10V Electrolytic Capacitor	022-119-9-004
Q401, 402, 403, 404 }	Transistor, NPN Silicon, Signal 2SC535-C	176-055-9-001
R404, 406, 424, 426 }	182 Ω , 1/4W, \pm 1% Metal Coated Resistor	013-010-9-014
VR401	100 Ω Potentiometer	008-292-9-002
VR402	100 Ω Potentiometer	008-282-9-004

MISCELLANEOUS

DESCRIPTION	B & K PART NO.
Bezel	380-338-9-003
Bezel Assembly	380-341-9-001
Bezel Frame	769-102-9-002
Case	272-149-9-001
CRT	230-009-9-001
Filter	380-338-9-001
Fuse, 0.3A	191-010-9-001
Fuse, 0.7A	191-011-9-001
Fuse Clip	742-031-9-001
Knob, "VOLTS/CM", "SWEEP TIME/CM"	751-186-9-001
Knob, "VARIABLE"	751-186-9-003
Knob, "INTENSITY", "FOCUS", "POSITION", etc.	751-186-9-002
Knob, Lever Switch	751-186-9-004
Line Cord	420-013-9-001
Vector Overlay	492-044-9-001
Transformer, Power	065-126-9-001

NOTE: Standard value resistors and capacitors are not listed. Values may be obtained from schematic diagram. Minimum charge \$5.00 per invoice. Orders will be shipped C.O.D. unless previous open account arrangements have been made or remittance accompanies order. Advance remittance must cover postage or express charges. Specify serial number when ordering replacement parts.

BK-PRECISION DYNASCAN CORPORATION
6460 W. Cortland Street, Chicago, Illinois 60635

P.C. BOARD

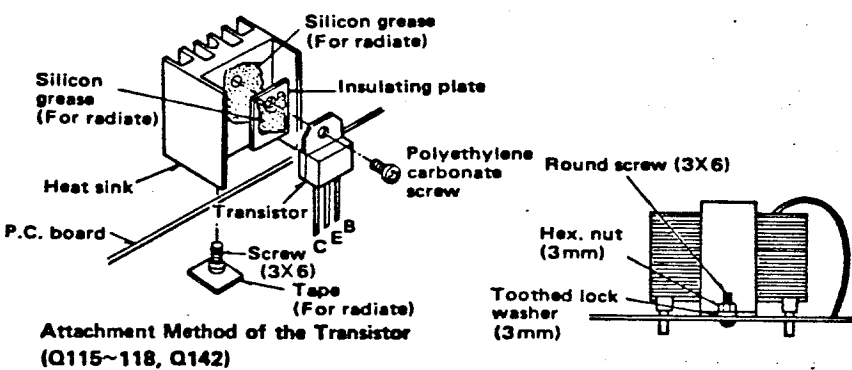
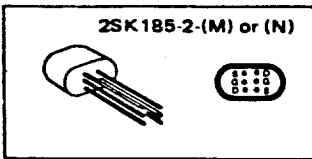
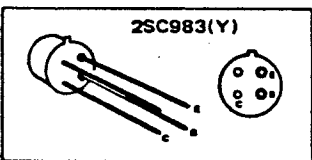
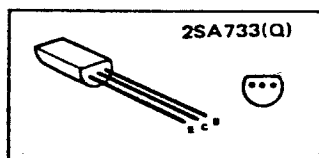
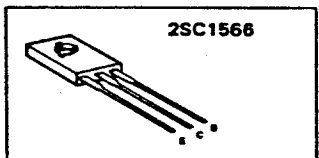
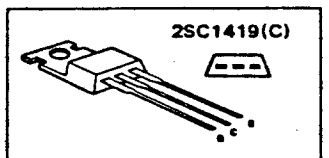
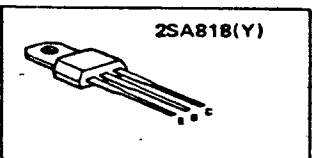
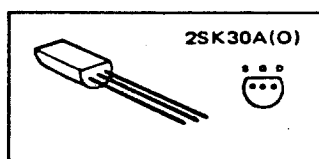
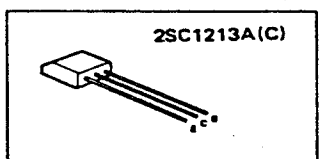
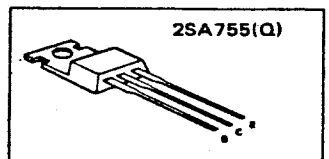
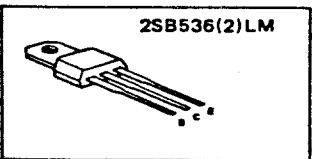
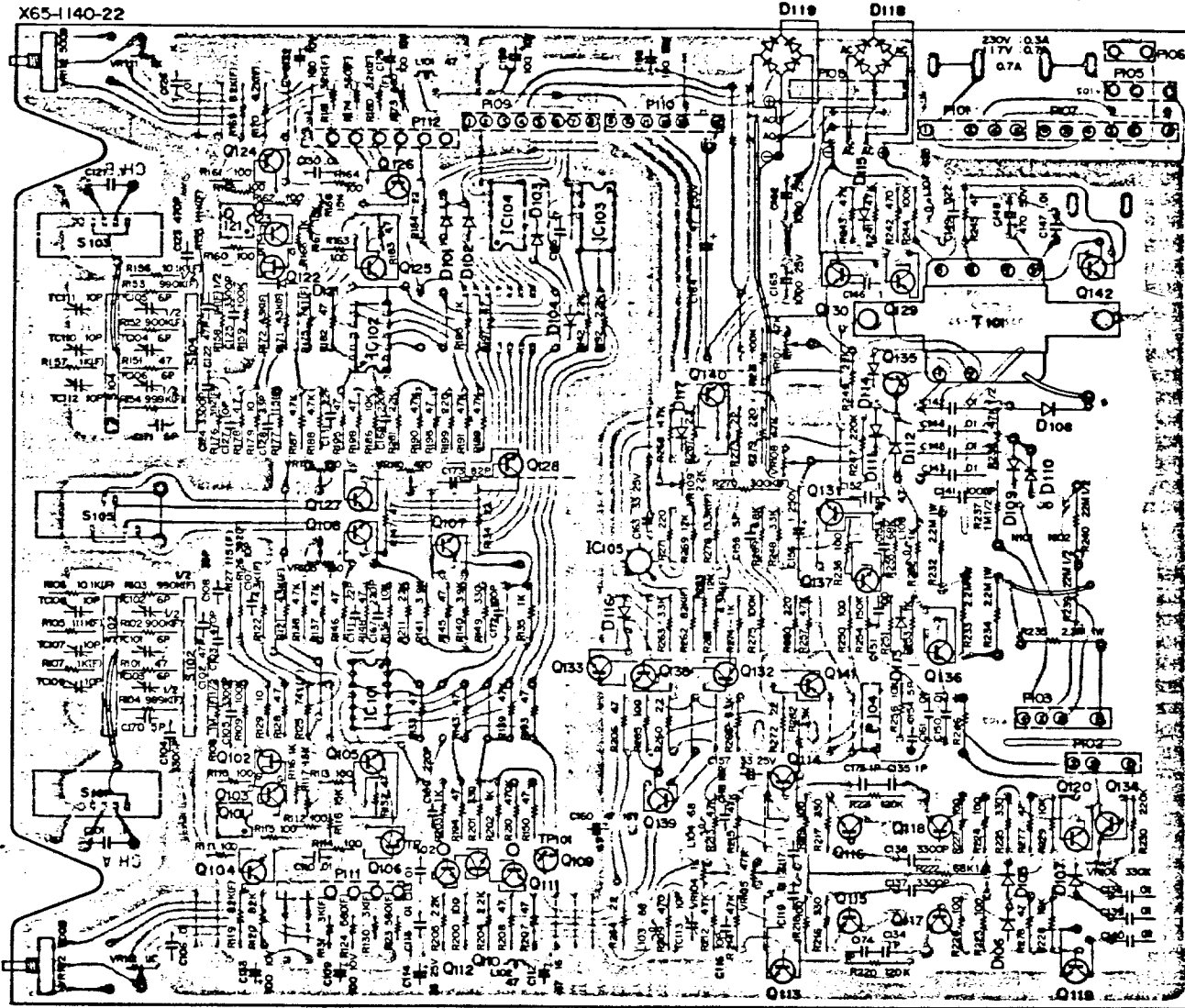

Attachment Method of the Transformer (T101)

P.C. BOARD

X74-1060-00

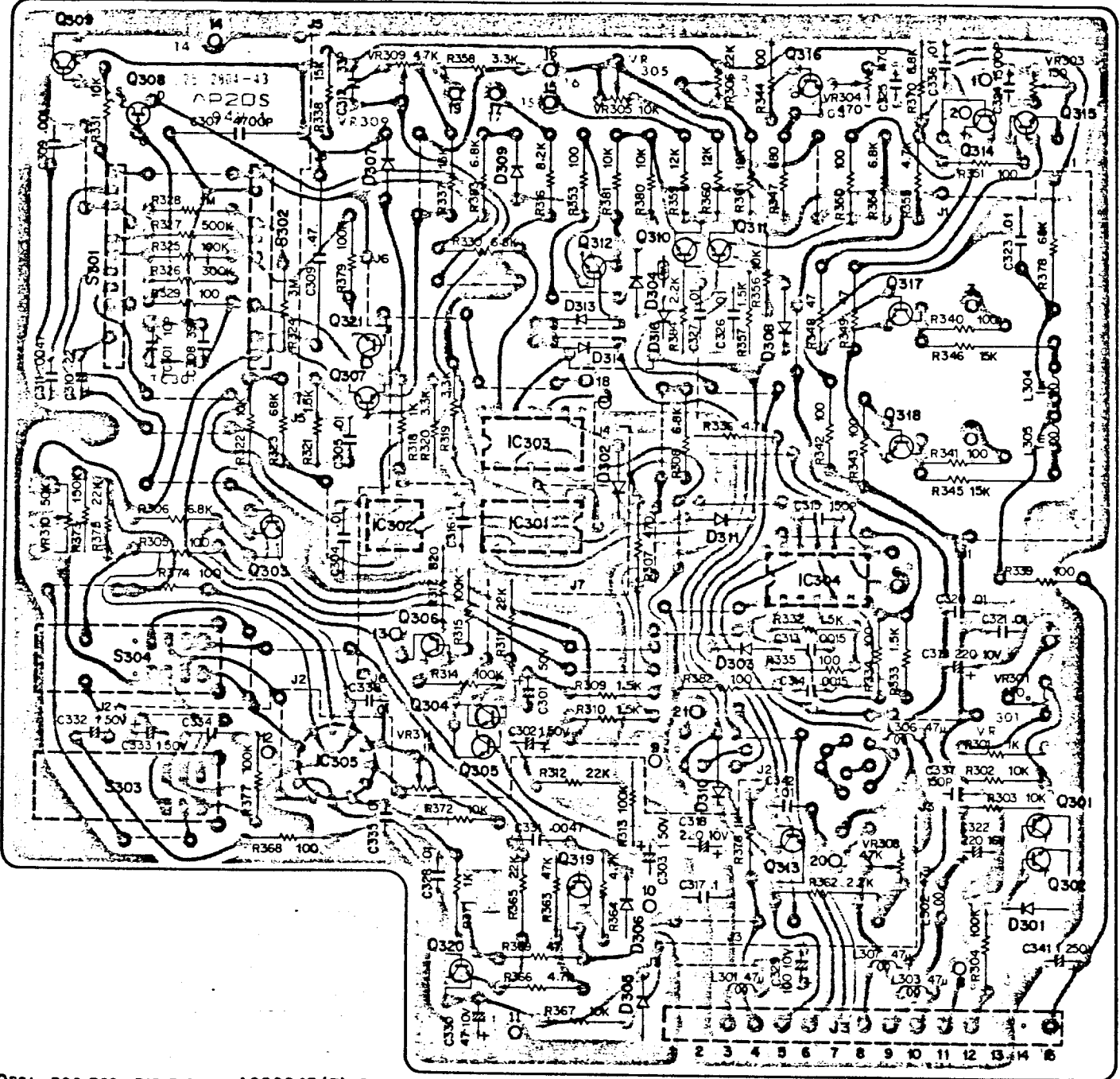

Q301~306, 309~316, 319~321: 2SC945 (P), Q307, 323: 2SA733 (Q), Q308, 322: 2SK30A (O), Q317, 318: 2SC1507
 D301~308, 308~315: 1S1555, D307: 1S1587, IC301: TD3472 AP, IC302: RC555DN, IC303, 304: TD3400AP, IC305: AN606

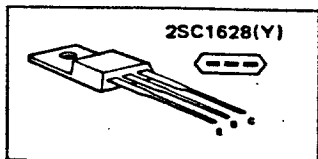
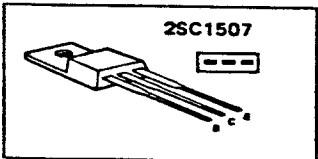

CIRCUIT DIAGRAM

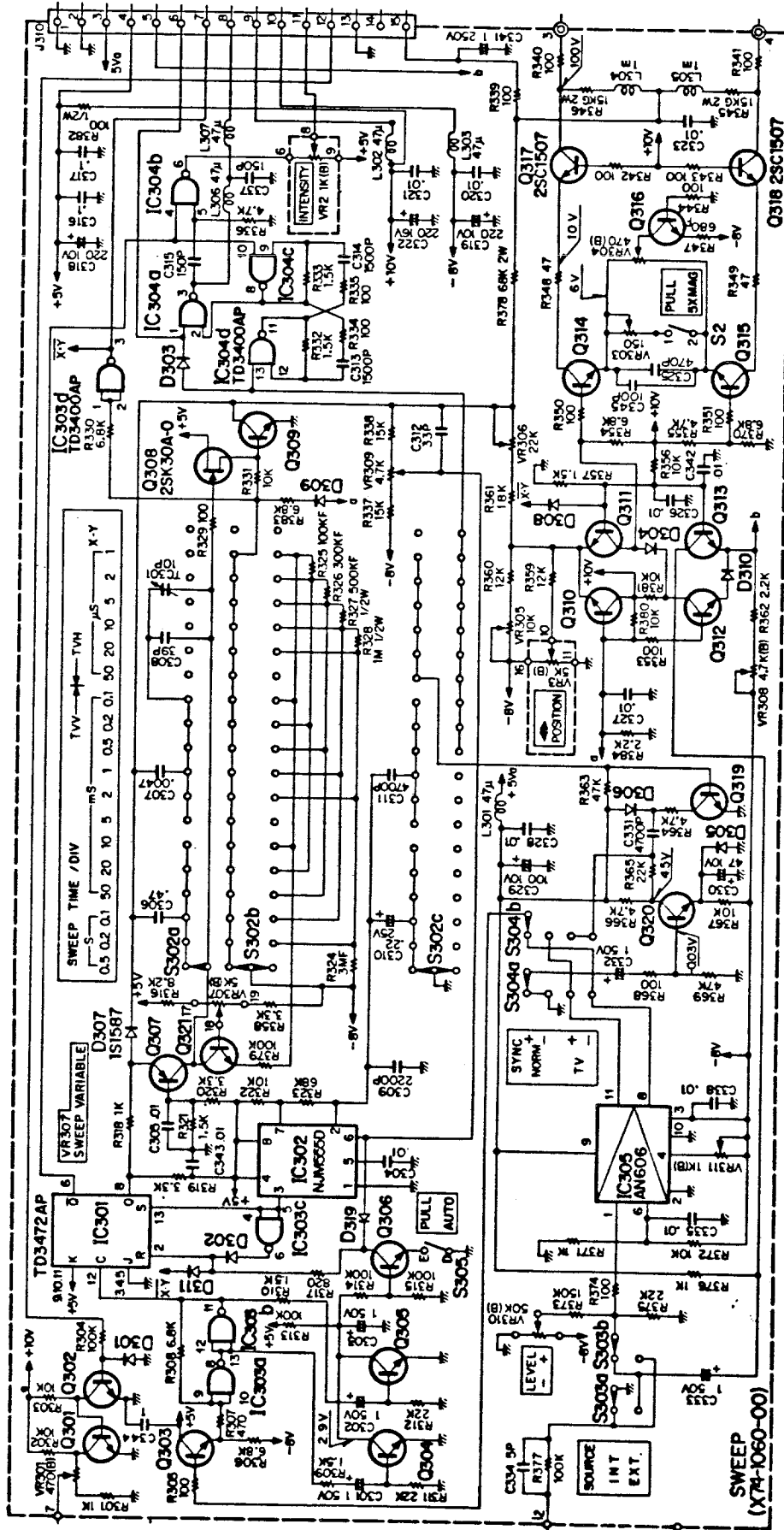

P.C. BOARD/CIRCUIT DIAGRAM

X73-1190-00

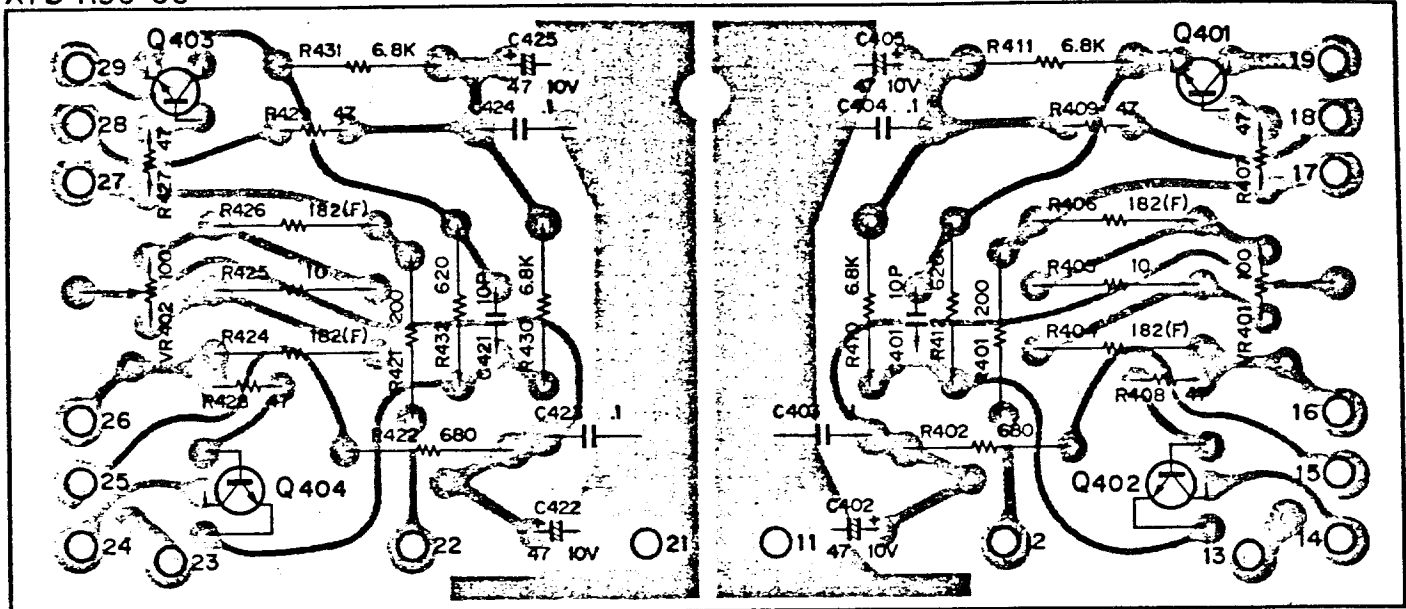

Q401-404: 2SC535C

(CH2 SIDE)

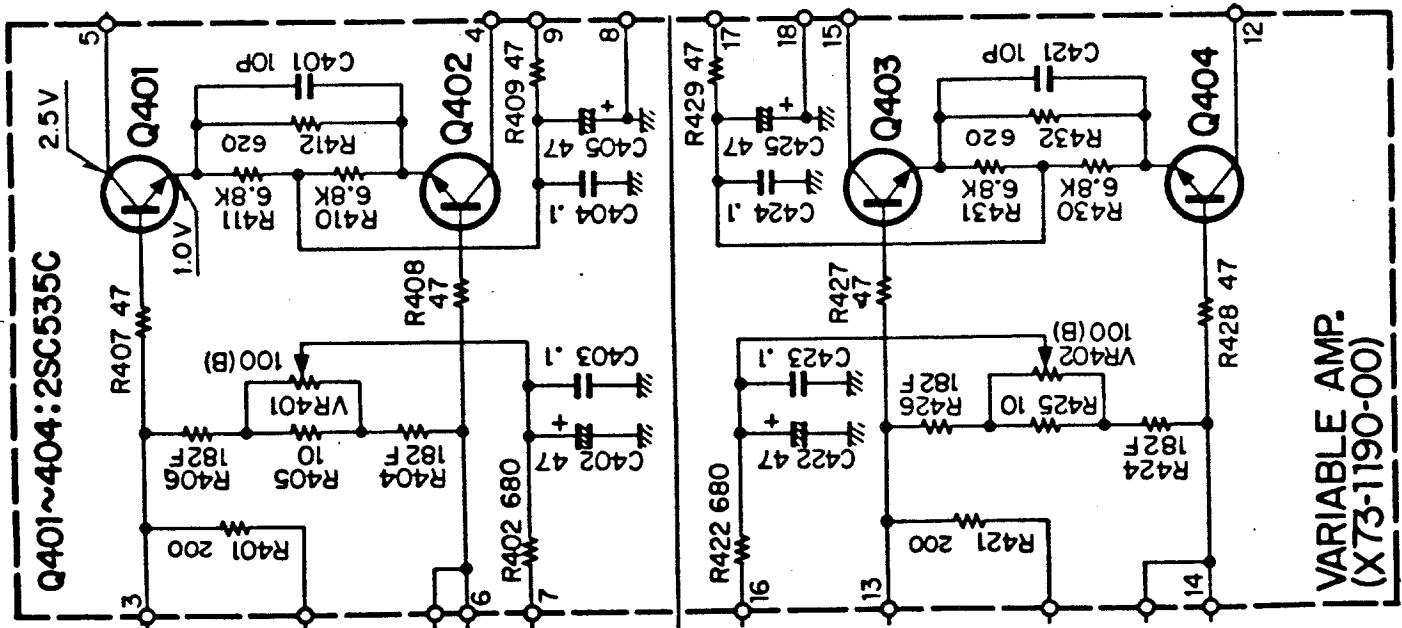
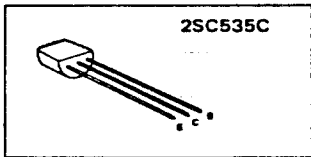

P.C. BOARD / CIRCUIT DIAGRAM

X73-1190-00

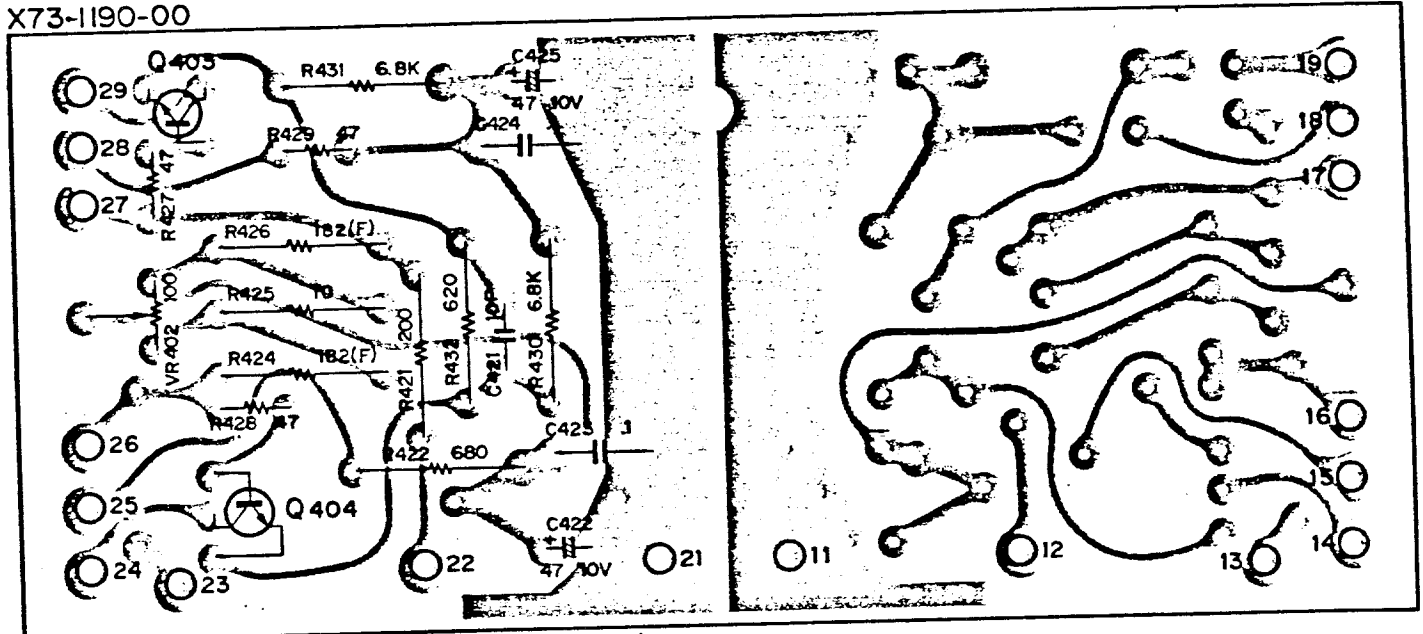

Q401-404:2SC535C

(CH2 SIDE)

(X73-1190-01)

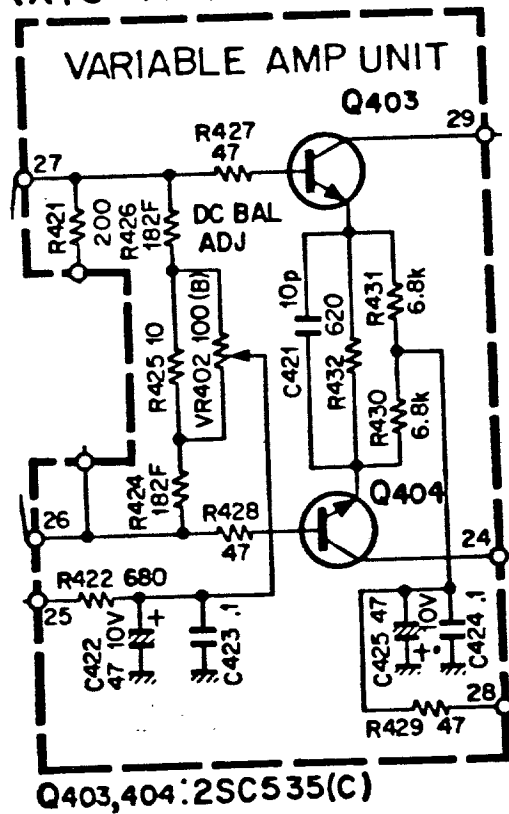

Q403,404:2SC535(C)

CIRCUIT DIAGRAM

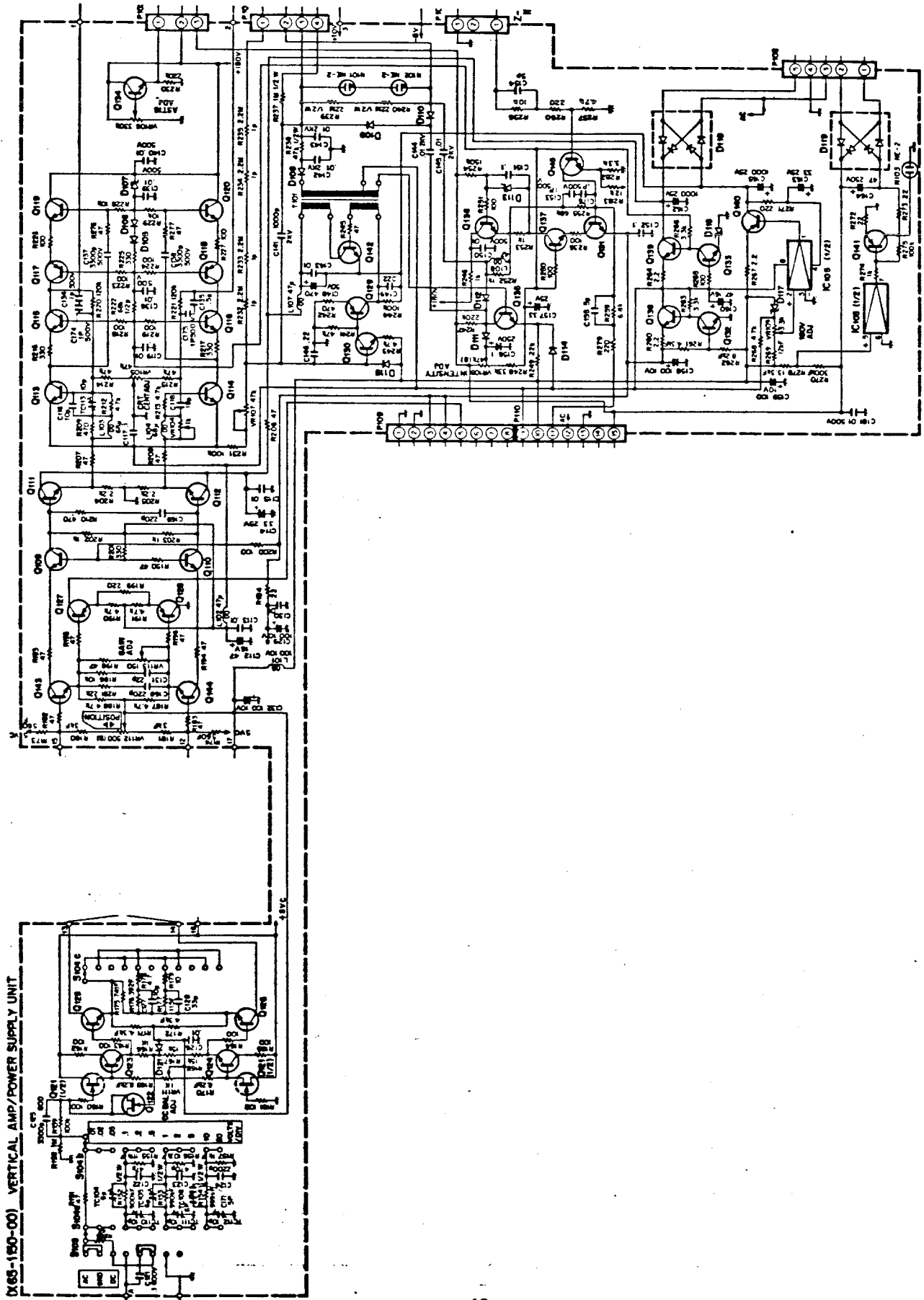

P.C. BOARD

X74-1060-01

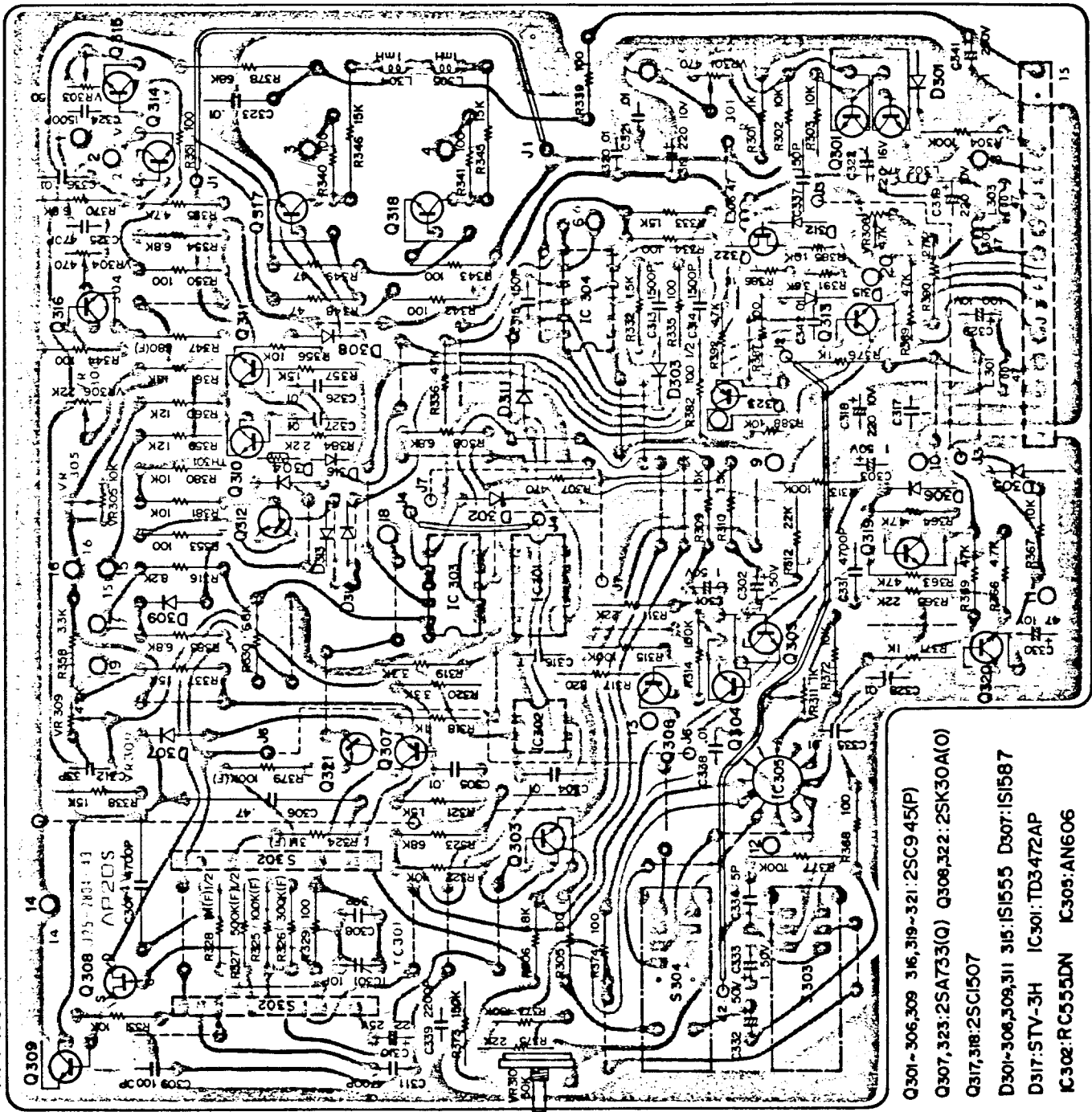

- Q301-306:309 316,319-321:25C945(P)
- Q307,323:25A733(Q) Q308,322:25K30A(O)
- Q317,318:25C1507
- D301-306,309,311 315:15I555 D307:15I587
- D317:5TV-3H IC301:TD3472AP
- IC302:RC555DN IC305:AN606

CIRCUIT DIAGRAM

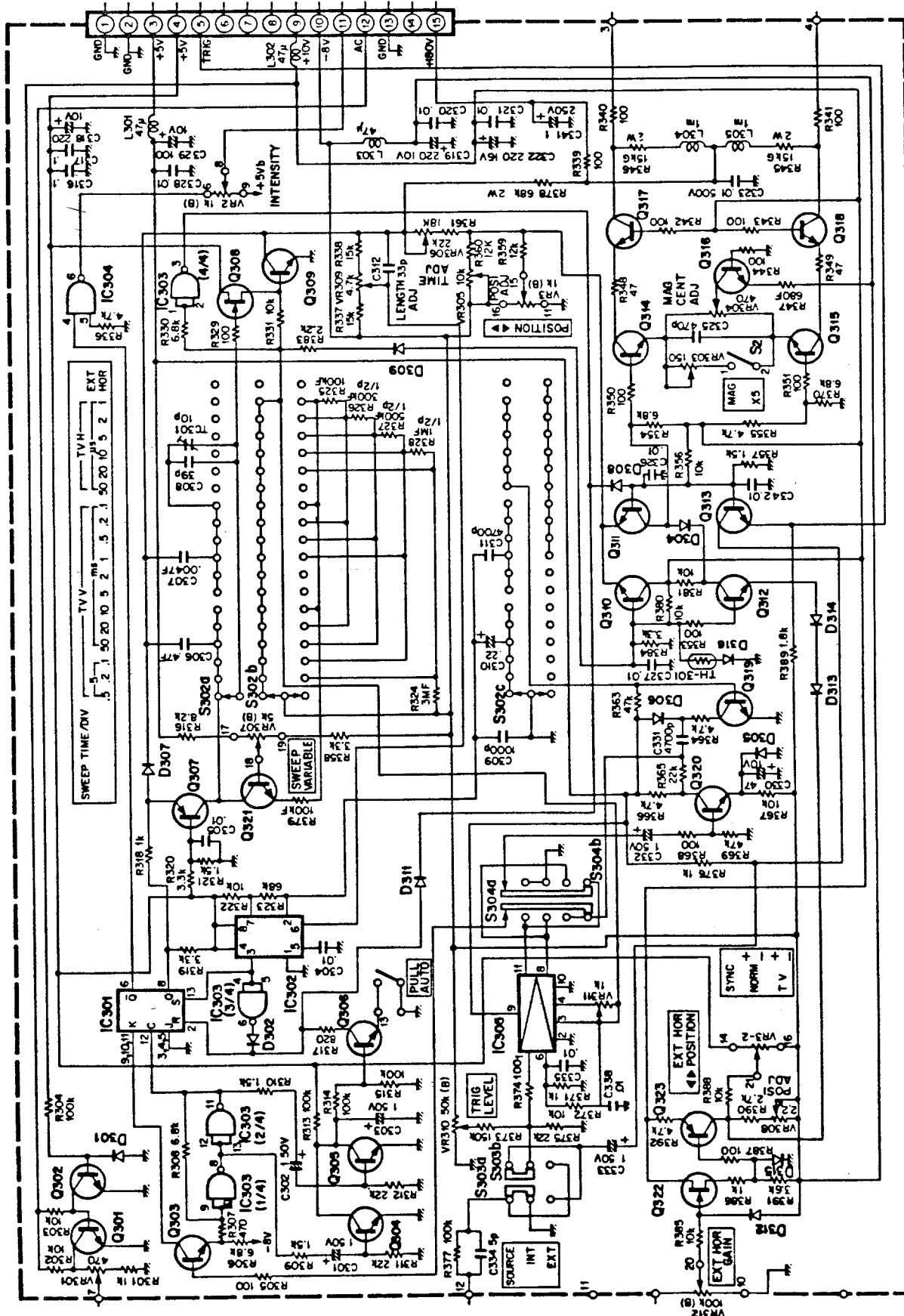

(X74-1060-01) SWEEP/HOR AMP UNIT

P.C. BOARD

X65-1150-00.1140

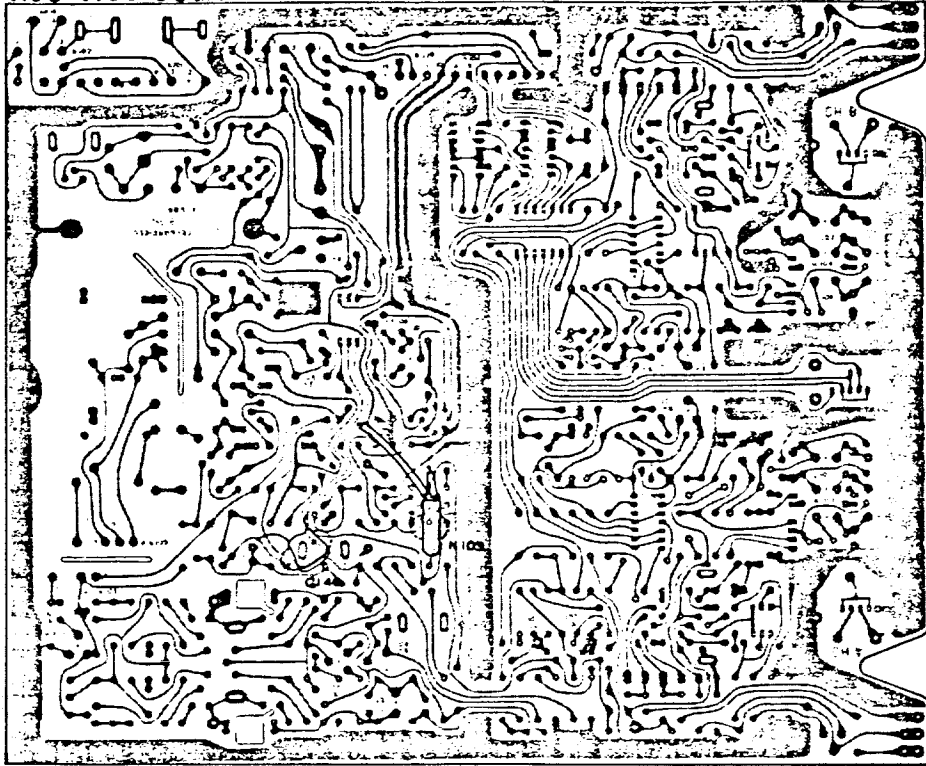

X74-1060-00.01

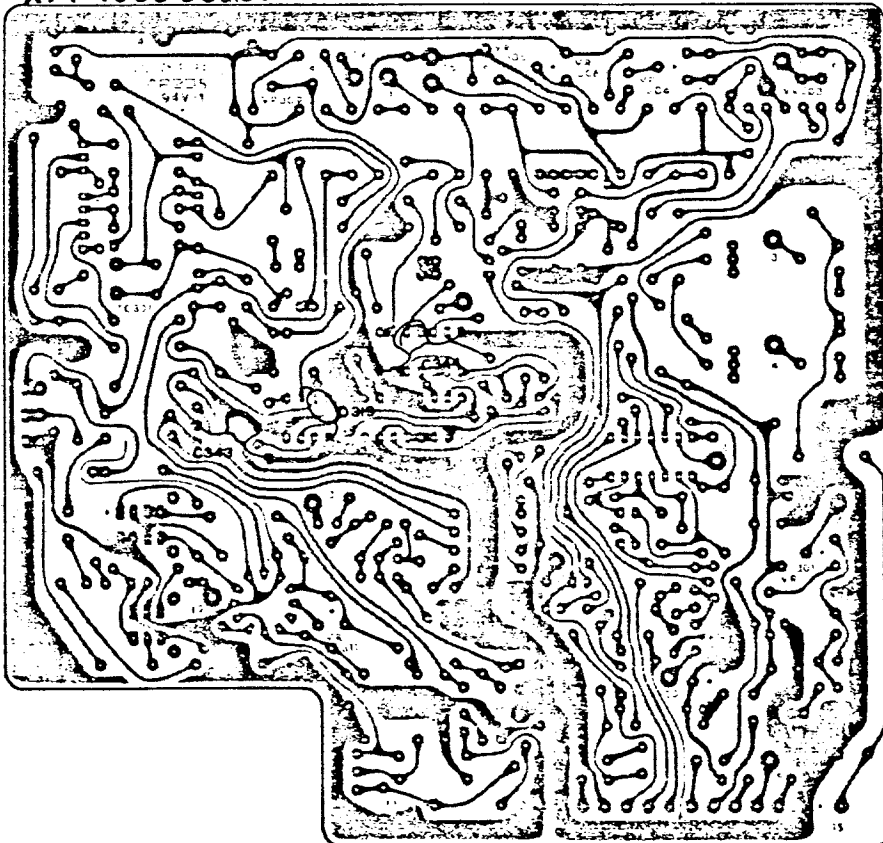

SCHEMATIC DIAGRAM Model 1466

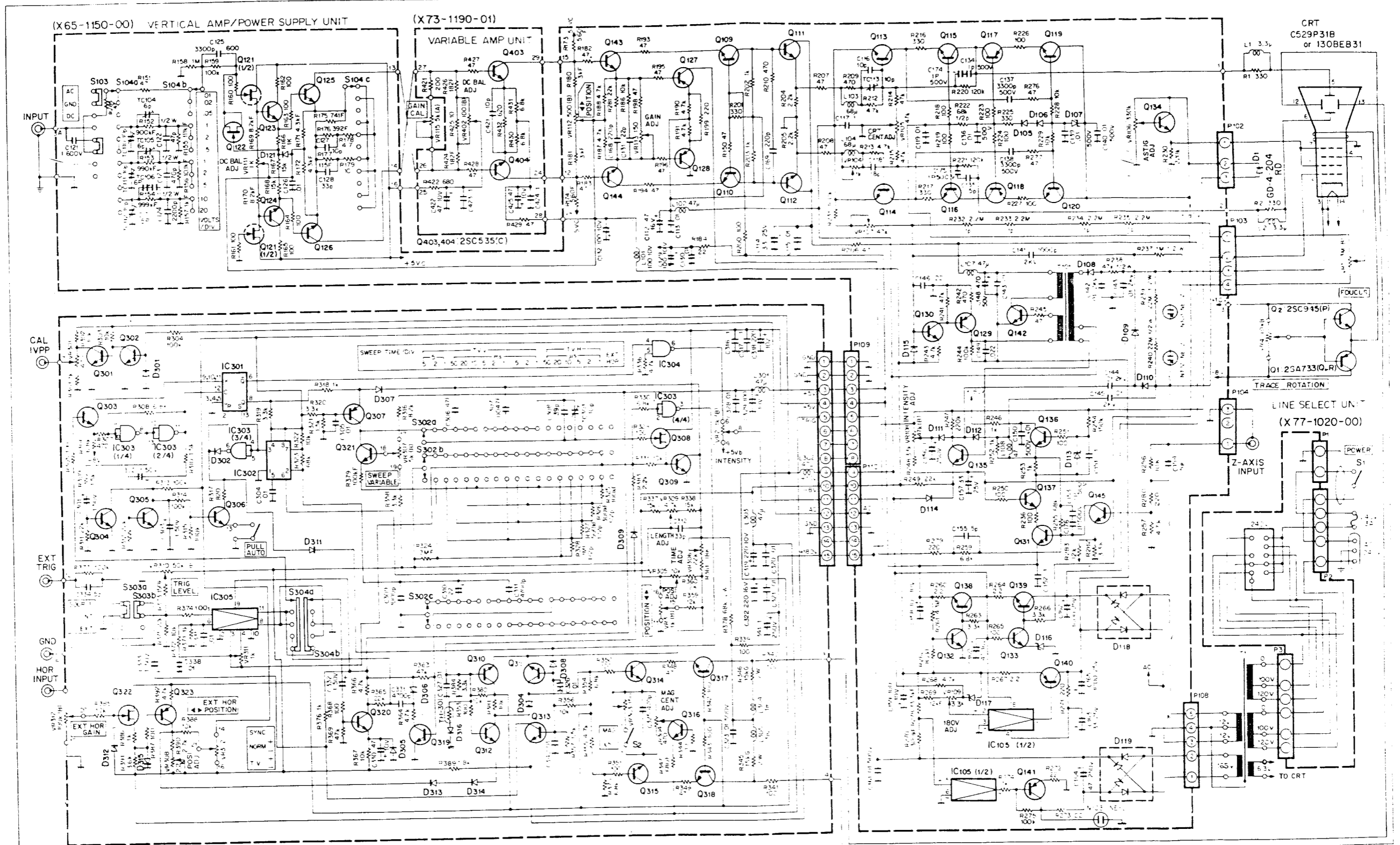

(X74-1060-01) SWEEP/HOR AMP UNIT

Q301~306, 309~316, 319~321: 2SC945(P), Q307, 323: 2SA733(Q), Q308, 322: 2SK30A(O), Q317, 318: 2SC1507
 D301~306, 308, 309, 311~315: 1S1555, D307: 1S1587, D316: STV-3H
 IC301: TD3472AP, IC302: NJM555D, IC305: AN606
 TH301: SDT-1000

Q109~112, 119, 120, 123, 124, 130, 132, 133, 143-145: 2SC945(P), Q113, 114: 2SC535(C), Q115, 116: 2SC1628(Y)
 Q117, 118: 2SA18(Y), Q121: 2SK185-2-(M) or (N), Q122: 2SK30A(O), Q125, 126: 2SC535(C), Q127~129: 2SA733(O)
 Q134, 135: 2SC983(Y), Q138: 2SC1213(C), Q139: 2SC1419(C), Q140: 2SA755(C), Q141: 2SB536(2) LM, Q141: 2SC535
 Q142: 2SD401, Q143, 144, 145: 2SC535(C), Q136, 137: 2SC1566
 D105, 106, 114, 115, 121: 1S1555, D107, 116: WZ-100, D108: Y16JA, D109~111: W06C, D112: 1S1705, D113: WZ-050
 D117: WZ-090, D118, 119: 1SQB60, IC105: RC4558T

RESISTANCE VALUES IN Ω , $k\Omega$, CAPACITANCE IN μF , F AND INDUCTANCE IN H UNLESS OTHERWISE SPECIFIED

SCHEMATIC DIAGRAM Model 1476

